

ENTERED NOV 09 2005
Ref# 05001213

United States Department of the Interior
National Park Service

NATIONAL REGISTER OF HISTORIC PLACES
REGISTRATION FORM

This form is for use in nominating or requesting determinations for individual properties and districts. See instructions in How to Complete the National Register of Historic Places Registration Form (National Register Bulletin 16A). Complete each item by marking "X" in the appropriate box or by entering the information requested. If any item does not apply to the property being documented, enter "N/A" for "not applicable." For functions, architectural classification, materials, and areas of significance, enter only categories and subcategories from the instructions. Place additional entries and narrative items on continuation sheets (NPS Form 10-900a). Use a typewriter, word processor, or computer, to complete all items.

1. Name of Property

Historic name The Selle Gear Company

Other names/site number The Akron- Selle Company

2. Location

street & number 451 South High Street N/A not for publication

city or town Akron N/A vicinity

state Ohio code OH county Summit code 153 zip code 44311

3. State/Federal Agency Certification

As the designated authority under the National Historic Preservation Act of 1986, as amended, I hereby certify that this nomination request for determination of eligibility meets the documentation standards for registering properties in the National Register of Historic Places and meets the procedural and professional requirements set forth in 36 CFR Part 60. In my opinion, the property meets does not meet the National Register Criteria. I recommend that this property be considered significant nationally statewide locally. See continuation sheet for additional comments.)

William Fawcett Department Head September 26, 2005
Signature of certifying official Inventory & Registration Date

Ohio Historic Preservation Office, Ohio Historical Society

State or Federal agency and bureau

In my opinion, the property meets does not meet the National Register criteria. (See continuation sheet for additional comments.)

Signature of commenting or other official Date

State or Federal agency and bureau

4. National Park Service Certification

I, hereby certify that this property is:

- entered in the National Register
- See continuation sheet.
- determined eligible for the National Register
- See continuation sheet.

- determined not eligible for the National Register
- removed from the National Register
- other (explain): _____

Signature of Keeper Date of Action

5. Classification

<p>Ownership of Property (Check as many boxes as apply)</p> <input checked="" type="checkbox"/> private <input type="checkbox"/> public-local <input type="checkbox"/> public-State <input type="checkbox"/> public-Federal	<p>Category of Property (Check only one box)</p> <input checked="" type="checkbox"/> building(s) <input type="checkbox"/> district <input type="checkbox"/> site <input type="checkbox"/> structure <input type="checkbox"/> object	<p>Number of Resources within Property (Do not include previously listed resources in the count)</p> <table border="0"> <tr> <td style="text-align: center;">Contributing</td> <td style="text-align: center;">Noncontributing</td> <td></td> </tr> <tr> <td style="text-align: center;">1</td> <td style="text-align: center;">0</td> <td>buildings</td> </tr> <tr> <td colspan="2"></td> <td>sites</td> </tr> <tr> <td colspan="2"></td> <td>structures</td> </tr> <tr> <td colspan="2"></td> <td>objects</td> </tr> <tr> <td style="text-align: center;">1</td> <td style="text-align: center;">0</td> <td>Total</td> </tr> </table>	Contributing	Noncontributing		1	0	buildings			sites			structures			objects	1	0	Total
Contributing	Noncontributing																			
1	0	buildings																		
		sites																		
		structures																		
		objects																		
1	0	Total																		

Name of related multiple property listing
 (Enter "N/A" if property is not part of a multiple property listing.)

N/A

Number of contributing resources previously listed in the National Register

N/A

6. Function or Use

<p>Historic Functions (Enter categories from instructions)</p> <p>INDUSTRY/PROCESSING (Manufacturing facility, processing, industrial storage)</p> <hr/> <hr/> <hr/> <hr/> <hr/> <hr/> <hr/> <hr/>	<p>Current Functions (Enter categories from instructions)</p> <p>WORK IN PROGRESS/VACANT/NOT IN USE</p> <hr/> <hr/> <hr/> <hr/> <hr/> <hr/> <hr/> <hr/>
---	--

7. Description

<p>Architectural Classification (Enter categories from instructions)</p> <p>Romanesque Revival</p> <p>Mixed</p> <hr/> <hr/> <hr/>	<p>Materials (Enter categories from instructions)</p> <table border="0"> <tr> <td style="vertical-align: top;"> Foundation roof walls </td> <td style="vertical-align: top;"> <p>STONE: Sandstone</p> <p>ASPHALT: shingles. Roll roofing.</p> <p>BRICK, GLASS, WOOD, METAL: aluminum, steel, CONCRETE, SYNTHETICS</p> <p>WOOD, CERAMIC TILE,</p> <hr/><hr/><hr/> </td> </tr> <tr> <td style="vertical-align: top;"> other </td> <td></td> </tr> </table>	Foundation roof walls	<p>STONE: Sandstone</p> <p>ASPHALT: shingles. Roll roofing.</p> <p>BRICK, GLASS, WOOD, METAL: aluminum, steel, CONCRETE, SYNTHETICS</p> <p>WOOD, CERAMIC TILE,</p> <hr/> <hr/> <hr/>	other	
Foundation roof walls	<p>STONE: Sandstone</p> <p>ASPHALT: shingles. Roll roofing.</p> <p>BRICK, GLASS, WOOD, METAL: aluminum, steel, CONCRETE, SYNTHETICS</p> <p>WOOD, CERAMIC TILE,</p> <hr/> <hr/> <hr/>				
other					

Narrative Description
 (Describe the historic and current condition of the property on one or more continuation sheets.)

8. Statement of Significance

Applicable National Register Criteria

(Mark "x" in one or more boxes for the criteria qualifying the property for National Register listing)

- A** Property is associated with events that have made a significant contribution to the broad patterns of our history.
- B** Property is associated with the lives of persons significant in our past.
- C** Property embodies the distinctive characteristics of a type, period, or method of construction or represents the work of a master, or possesses high artistic values, or represents a significant and distinguishable entity whose components lack individual distinction.
- D** Property has yielded, or is likely to yield information important in prehistory or history.

Criteria Considerations

(Mark "X" in all the boxes that apply.)

Property is:

- A** owned by a religious institution or used for religious purposes.
- B** removed from its original location.
- C** a birthplace or a grave.
- D** a cemetery.
- E** a reconstructed building, object, or structure.
- F** a commemorative property.
- G** less than 50 years of age or achieved significance within the past 50 years.

Narrative Statement of Significance

(Explain the significance of the property on one or more continuation sheets.)

Areas of Significance

(Enter categories from instructions)

INDUSTRY

INVENTION

TRANSPORTATION

ARCHITECTURE

ENGINEERING

Period of Significance

1887 – 1955

Significant Dates

1887, 1901-1902, c. 1907, 1918-1920, c.1943

Significant Person

(Complete if Criterion B is marked above)

Cultural Affiliation**Architect/Builder**

UNKNOWN, 1902 ADDITION BY FRANK O. WEARY, architect, H.H. HENNINGER, contractor

9. Major Bibliographical References

Bibliography

(Cite the books, articles, and other sources used in preparing this form on one or more continuation sheets.)
Previous documentation on file (NPS)

- preliminary determination of individual listing (36 CFR 67) has been requested.
- previously listed in the National Register
- previously determined eligible by the National Register
- designated a National Historic Landmark
- recorded by Historic American Buildings Survey

- recorded by Historic American Engineering Record

Primary location of additional data

- State Historic Preservation Office
 - Other State agency
 - Federal agency
 - Local government
 - University
 - Other
- Name of repository: Chambers, Murphy & Burge Restoration Architects

10. Geographical Data

Acreege of Property 3.247 acres

UTM References

(Place additional UTM references on a continuation sheet)

- | Zone Easting Northing | Zone Easting Northing |
|----------------------------|-----------------------|
| 1 <u>17 456130 4546833</u> | 3 |
| 2 _____ | 4 |
- See continuation sheet.

Verbal Boundary Description

(Describe the boundaries of the property on a continuation sheet.)

Boundary Justification

(Explain why the boundaries were selected on a continuation sheet.)

11. Form Prepared By

name/title organization YOLITA RAUSCHE, Historic Preservation Specialist, CHAMBERS, MURPHY & BURGE RESTORATION ARCHITECTS. Emily Stein, Chad Solon, Amy Darkow, Kelly Shaulis (Graphics, research)
date November, 2004

street & number 43 EAST MARKET STREET SUITE 201 telephone 330.434.9300

city or town AKRON state OH zip code 44308

Additional Documentation

Submit the following items with the completed form:

Continuation Sheets

Maps

A **USGS map** (7.5 or 15 minute series) indicating the property's location.

A **Sketch map** for historic districts and properties having large acreage or numerous resources.

Photographs

Representative **black and white** photographs of the property.

Additional items

(Check with the SHPO or FPO for any additional items)

Property Owner

(Complete this item at the request of the SHPO or FPO.)

name TODD W. EDERER, SELLE GENERATOR WORKS, LTD.

street & number 34 MERZ BLVD. SUITE A telephone 330.8364951

city or town AKRON state OH zip code 44333

Paperwork Reduction Act Statement: This information is being collected for applications to the National Register of Historic Places to nominate properties for listing or determine eligibility for listing, to list properties, and to amend existing listings. Response to this request is required to obtain a benefit in accordance with the National Historic Preservation Act, as amended (16 U.S.C. 470 et seq.).

Estimated Burden Statement: Public reporting burden for this form is estimated to average 18.1 hours per response including the time for reviewing instructions, gathering and maintaining data, and completing and reviewing the form. Direct comments regarding this burden estimate or any aspect of this form to the Chief, Administrative Services Division, National Park Service, P.O. Box 37127, Washington, DC 20013-7127; and the Office of Management and Budget, Paperwork Reductions Project (1024-0018), Washington, DC 20503.

United States Department of the Interior
National Park Service

NATIONAL REGISTER OF HISTORIC PLACES
CONTINUATION SHEET

Section number 7
Selle Gear Company
Summit County, Ohio

Page 1

The Selle Gear Company building complex of approximately 70,000 square feet is still located on its original site, on the southwest corner of the original South Akron founded by Simon Perkins and Paul Williams in 1825. Today it is situated on block south of Akron's growing CBD boundaries. It is surrounded by newly rehabilitated industrial and office building complexes and expansive parking lots. The recently widened and elevated S. Broadway Street separates the Selle Gear Complex from the former railroad tracks which were used by the most important rail lines (New York Penn & Ohio RR, Akron & Chicago Junction RR, Cleveland Akron and Cincinnati RR) passing through Akron, and the freight station. There is a sand and gravel extracting company towards the south, the former low marshy grounds, which was formerly the lower basin connected to the Ohio & Erie Canal below Lock N° 1. All the existing surroundings represent the industrial development in South Akron during Akron's Gilded Age in the 19th century, the rubber boom of the early 20th century, the urban renewal of the 1960's and the rehabilitation of the former industrial sites in the 1990's at Akron's former Lower Basin of the Ohio Erie Canal.

The Selle Gear Company was built in 1887 (**Historic Photo 1**) and its continuous economic growth until the end of WWII produced a building expansion towards the north, to the former E. Chestnut St. (today Selle St.). The architect and contractor are unknown. The first expansion occurred in 1901 and 1902 respectively with architect Frank O. Weary's one story and two story shed additions on the south; the second in c. 1907 which was a small one story addition to the south of the 1901 addition, and a four story annex separated by a wood frame skyway to the north connecting the third floors (**Photo 1**); the third addition was of two one story structures built in c.1918 to the north of the c.1907 structure; the fourth was a one story fireproof section built in 1920 facing (Selle St.) connected to both 1918 buildings and forming a square complex, and the fifth addition, to the west, was a large one story steel structure with glass walls built in c.1943, facing Selle St. and the corner with S. High St. (**Historic Photo 3**).

The Selle Gear Company is a complex of red brick industrial structures (**Photo 2**). The complex consists of four major sections on a block wide site bounded by South High Street, South Broadway Street and Selle Street. The site contains a grade change of approximately two stories between the northeast corner (the corner of S. Broadway St. and Selle St.) and the southwest corner. The site was developed from south to north with the original building addressing the S. High St and Selle St. corner.

1887 Building Section

The original masonry building, built in 1887(**Photo 3**), consists of three sections located at the south end of the complex. The largest is a four story rectangle with a gabled roof with two chimneys symmetrically placed at the west and east ends respectively (**Photo 4**). The ghost of the original name that had been painted on the building can be seen in the east and west facades (**Photo 5**): the logo can be seen in the west gable (**Photo 6**). All the floors are connected by wood stairs surrounding a freight elevator. The wood square columns support wood floors. The exterior walls are exposed brick. Every floor has the typical open space of the industrial buildings of the 19th century surrounded by tall rectangular windows, where light was supposed to reach every corner of the floor (**Photo 29**). The original door facing S. Broadway Street is still in place, but is not in use (**Photo 7**). The shipping and storage was located on the 4th floor; the bench works on the 3rd floor, the machine shops were on the 2nd floor, and the 1st floor was used as storage for malleable iron. By 1927, the 3rd and 4th floors became also machine shops with machines like the Peerless cutting saw machine (**Historic Photos 4-8**). West of this main structure is a one and a half story gabled section matching the larger section in width (**Photo 8**). This wing used to be part of a 125' long blacksmith shop which was mostly destroyed by the tornado of 1943. The remaining 1887 structure, which was originally used for storage, is still supported by original wood trusses (**Photo 9**). The third remaining section to the south, a one story rectangular low pitched gable roof, is the former power plant (**Photo 10**). It housed the steam room, engine room, coal room, scrap wood and shaving vault. A 95' chimney is part of this section (**Photo 11**). It is located to the south of the main 1887 building. The main structure's facade is subdivided horizontally into three areas. Because of the topography, the first floor is below street grade at the east end (S. Broadway St.) (**Photo 12**) and at grade at the west end (S. High St.). The northeast elevation of the 1887 building has an elaborate ashlar sandstone base punctured with small rectangular windows. This was the result of the high embankment at that time. Tall double hung windows are present at the northwest end of the same elevation, towards S. High St.

United States Department of the Interior
National Park Service

NATIONAL REGISTER OF HISTORIC PLACES
CONTINUATION SHEET

Section number 7
Selle Gear Company
Summit County, Ohio

Page 2

The second floor, composed of bays of two double hung windows each with stone sills, has a stone stringcourse acting as the lintel and also divider from the upper floors. The second floor facing S. Broadway Street used to reach the street level by an earth filled ramp (**Historic Photo 1**), as well as the second floor section facing the Southeast corner. The upper two floors are grouped into bays, framed with corbeled brick and pilasters. Each bay contains two 1/1 double hung windows at each floor with individual sandstone sills and segmental arch lintels consisting of two rowlock courses of brick (**Photo 13**). The roof end has a small simple corbeled cornice. The original part of the Selle Gear Building represents the typical industrial building type used during Akron's economic expansion after the Civil War. Its stylistic features represent the Romanesque Revival period. This style was used extensively in Akron not only on churches, but on some industrial buildings.

1901 and 1902 Frank Weary Building Additions

The smaller one story and two story rectangular portions to the south, part of the 1901 and 1902 Frank O. Weary additions, have a variety of windows today, which includes small rectangular windows and double hung windows placed individually and in groupings. These windows all have segmental arch openings similar to those on the four story block. In 1901, the one story addition was specified as an addition to the south side of the smith shop (blacksmith shop). This one story addition became the forging room, of which only the storage portion remains after the tornado of 1943. The following year, a two story brick addition was added to the east, and next to it, a second story was added on top of the bending room of the one story power plant on the south elevation (**Photo 10**). The specifications by Frank Weary for the new foundation of these additions reflected the use of concrete, an emerging material in the 20th century, and the flat roofs were specified to be covered with asphalt, gravel or rolled roofing. New steel frame skylights were installed on the forging room's storage area and the two story brick expansion, which were later removed after the 1943 tornado.

1907 Building Annex and Addition

The brick annex to the north of the original building is connected by a bridge (**Photo 1**) on the 3rd floor (**Photo 14**). This annex was built after becoming the Akron-Selle Co. The 1907 building has a rectangular footprint and a flat roof with a parapet. The east end of the south elevation has five window bays and is four stories high. The remaining two window bays towards the west are only three stories high. The fourth floor was removed due to storm damage according to the present owner. There is a grade change of nearly two stories between the north and south elevations of this building. The lowest level, the first floor, visible on the south and east elevations, is defined by bays of tall three double hung windows framed by wide segmental arch lintels and brick sills. Towards the west, on the south elevation there is a rectangular double door, then, at the center is the elevator shaft double door which is boarded up, and followed to the east by an elevated double door used as a loading area. There is another double door on the east elevation facing an old unused railroad spur parallel to S. Broadway Street. The second level, of the south elevation has the same configuration without the doors, but with shorter windows. The last two floors of the south elevation, towards the east, are separated by a stone belt course and have brick pilasters separating their bays of three double hung windows with the corresponding segmental arches. Corbeled bricks terminate each bay except the last two bays towards the west, where the elevation was rebuilt. The five bays to the east have a corbelled dentilled brick cornice (**Photo 15**), an architectural feature related to the original 1887 building. There is a ghost mark, between the first floor and second floor, of a former roof line of a one story enclosure between the two buildings (1887, c.1907). This space was used as storage for iron stock. The small enclosed frame bridge (skyway) connects the third floor to the original building (**Photo 16, 17**). The four story, three bay, east elevation on S. Broadway St. repeats the bay design already described. The two story, three bay, west elevation facing S. High St lacks the corbeled ornamentation, the pilasters and the belt course (perhaps the result of the later storm damage rehabilitation). The interior wood frame structure is supported by wood posts with cast iron caps. This annex has concrete and brick floors on the first floor and wood on the rest of the floors, as in the original 1887 building. The first floor and second floor of the 1907 building were used for wagon stock, the third floor was used for office and trim shop and the fourth floor was used as paint shop and later it had lacquer spray booth space in addition to manufacturing (**Photo 28**). The 1907 annex has the influence of the utilitarian architecture predominant at the turn of the century, when the expanses of glass surfaces were increasing. The scale, material, color and architectural details created a continuity with the original building.

United States Department of the Interior
National Park Service

**NATIONAL REGISTER OF HISTORIC PLACES
CONTINUATION SHEET**

Section number 7
Selle Gear Company
Summit County, Ohio

Page 3

At that time, a small one story addition was added to the south of the 1887 building, which was used as a furniture room and later as a forge shop. Today, it defines the southwest corner of the Selle building complex.

1918-1920 Building Complex Addition

The next addition, a complex to the north, was constructed in c.1918 and 1920 connecting with the north side of the four story c.1907 annex (**Photo 18, 19**). It was built during Akron's most important physical and economic growth. These new additions consist of three connected one story rectangles that leave an almost square foot print. The main 1918 section is situated on the corner of South Broadway Street and Selle Street with the longer side along South Broadway Street. This section has a camelback slightly arched tension cord truss roof which provided space to machinery that were connected to tracks above the main space of the factory floor (**Photo 20**) (**Historic Photos 9-11**). The symmetrical north elevation on Selle St. has a false front that follows the shape of the truss above the roof line (**Photo 21**). The exposed brick and Kallwall steel framed elevations are bays of factory style steel multipaned windows set in corbeled brick recesses. The other two rectangles, part of this addition, are set perpendicular to the first and are both approximately the same size. The 1918 section to the south has the same false front elevation as the one on Selle St., but facing S. High St. Its steel camelback truss roof has steel frame wire glass skylights along the inclined end post (**Photo 22**). This addition faces S. High St. with large multipaned steel windows, with sandstone sills and steel lintels. The third part of this addition, to the north of the 1918 additions, faces Selle St. It was built in 1920 and was considered of fireproof construction with a concrete flat roof, columns and floors, and brick walls (**Photo 23**). It has a flat parapeted roof and multipaned industrial steel windows (fixed, pivoted or projecting) with Kallwall translucent panes, that resemble those on the corner section. This complex was designated as the factory building of the Akron-Selle Co. serving the automobile industry by manufacturing "truck bodies".

1943 Building Addition

The newest section of the Akron-Selle building complex was built during World War II (**Photo 24**). This portion of the building is located along Selle Street and connects to the 1918 and 1920 additions. It is a taller steel frame building with a low pitch gabled roof of Howe steel trusses supported by steel columns and enclosed by a brick and steel frame glass window wall (precursor to the curtain wall system), today insulated and sided with vertical metal siding and concrete floors. The Akron-Selle Co. was very busy during WWII manufacturing parts for the military. This section consists of a long, approximately 30' tall, one story rectangle and a lower shed roofed rectangle to the south abutting the 1918 addition (**Photo 25, 26**). Large factory steel windows which extend from the brick base to the ceiling structure can be seen in the interior (**Photo 27**). Akron-Selle Co. continued expanding its metal stamping production started in the 1920's. They provided also "blanking, drawing and forming from all metals". This latest addition represents the industrial building technology of the 1940's where manufacturing for the war effort took place. The production of metal stamping continued after WWII.

Most of the interiors of the Selle Building Complex consist of some painted brick walls and some unpainted brick and stone. The original 1887 building and first addition (1907) after the merger with Akron Gear, have wooden and brick floors. The 1907 building has also concrete floor on the first floor. All the later additions have concrete floors and expose the different types of steel structures used. The 1920's concrete fireproof addition has all of its interior surfaces exposed (**Photo 23**). The ground floors consist of large open spaces with loading dock openings in most of the building sections.

Exterior changes to the 1887 Selle Gear Co.:

- New aluminum window sash of 1/1 lights installed within the original frame opening, but with a solid upper sash, on all floors, except the third floor. They replace original multipaned of 9/9 lights, double hung wood windows.
- The tornado of 1943 destroyed the one story blacksmith shop with the 1901 Weary addition, approximately 105' of the old building (90%) was damaged and removed. There are still some remains of the brick floor on the site.

United States Department of the Interior
National Park Service

NATIONAL REGISTER OF HISTORIC PLACES
CONTINUATION SHEET

Section number 7
Selle Gear Company
Summit County, Ohio

Page 4

-
- The original slate roof of the 4 story structure was replaced with asphalt shingles after 1940. The original slate roof of the blacksmith shop was replaced with asphalt between 1904 and 1916. The metal roof of power plant replaced with asphalt between 1904 and 1916.

Exterior changes to the 1901-1902 Weary addition:

- New window sash of 1/1 lights built within original frame opening, but with a solid upper sash, replacing multipaned windows.
- One story forging room addition destroyed (90%) in the tornado of 1943. New Garage doors installed facing S. High Street.
- New large window opening installed on second floor.
- Windows and doors on first floor facing south were boarded up. Windows on the second floor facing S. High St. were also boarded up.

Exterior changes to c.1907 Annex:

- New triple windows of 1/1lights, double-hung, with solid upper sash (except on the third floor) replaced the original ones.
- Loss of a fourth floor section, the last two bays facing S. High St. after lightening damage.
- Windows were boarded up on the south of Weary's 1902 forge room addition.
- The one story iron stock storage with skylights was removed after 1940. This space is located between the two buildings (1887 and 1907), below the skyway. Only the stone floor remains.

Exterior changes to c.1907 one story addition to 1887 building.

- New aluminum windows with solid upper sash are boarded up. Some original arched fenestration is bricked in.

Exterior Changes to c.1918, 1920 Additions

- The original multipaned industrial glass windows were replaced by Kallwall material in the 1970's, after the energy crisis of 1973.

Exterior changes to c.1943 Addition

- Vertical metal siding was added above insulated glass window walls on the gabled addition, pierced by small sliding windows.
- A small, one story 15' x 24', loading dock was added to the SW corner, in c.1975.

The interior of the Selle Gear Co. did not undergo visible changes. The large open factory spaces are still filled with some machinery and equipment, like the Bliss DB Cran 500 Press Machine, as well as some wagons (**Photo 20**). The Bliss machine, because of its size was located in the larger 1943 structure (**Photo27**). Most areas are affected by water infiltration. Significant damage is observed in the 1902 Weary additions. Interior pulleys, steel rails used in the manufacturing process and structural reinforcement system are still in place on the 1st, 3rd and 4th floors of the 1907 addition as representatives of its industrial past. Significant engineering features still in existence are the single-strut trussed beams and double-strut trussed beams on the 4th floor used. These structural members under compression were used for saving larger spans, over 30' (**Photo 28**). They are shaped in the form of a shallow post truss which includes one or two vertical struts, two or three strut beams and a tie rod with turnbuckle. The integrity of the c.1943 addition has been affected by the vertical metal siding covering the glass walls, in a way protecting the original fabric. The new siding is a reversible change.

Overall, the Selle Gear Co. has maintained its architectural integrity as a 19th century industrial building of the railroad and canal legacy era of Akron. It also has served the needs of the automotive industry in the 20th century.

**United States Department of the Interior
National Park Service**

**NATIONAL REGISTER OF HISTORIC PLACES
CONTINUATION SHEET**

Section number **8**
Selle Gear Company
Summit County, Ohio

Page 1

The Selle Gear Company operated at the same Akron location for 110 years, while transportation changed from horse drawn carriages to automobiles. Initially, as manufacturers of carriage hardware and later of automotive hardware, the Selle Gear Company, unlike many of its contemporaries, successfully adapted to the new technology and grew rapidly during Akron's transportation related manufacturing boom. The Selle Gear Co. building is nominated for listing on the National Register under Criteria A and C. It qualifies under Criteria A, because of its association with historical events related to the evolution of the transportation manufacturing industry in the city of Akron and the establishment of new industries in South Akron, prompted by the development of new transportation technology, the expansion of the railroad and the canal legacy.

Among the areas of significance under criteria A, the Selle Gear company distinguishes itself for its significance under industry, because of its contributions in the manufacturing of important parts for the transportation industry like its famous wagon platform gearing which lead to its founding and into the evolution of the factory to the manufacturing of parts for the automobile industry, like the gages for gasoline tanks. The Selle Gear Company also significant in the area of transportation. Originally, the Selle Gear Co. was involved in manufacturing patented parts for wagons and carriages, in the 19th century and early 20th century and later parts for automobiles and trucks, a transportation mode of the 20th century. The Selle Gear Company is significant also in the category of invention. Ferdinand Selle was one of the great inventors of the Second Industrial Revolution in the 19th century and the Selle building would not be in existence today without his creative contribution. But also the continuity of its industrial survival would not have been possible without the vision of the leadership of the Selle Gear Co. who saw its future in transportation manufacturing and decided to purchase a variety of patents from different inventors across the country. In the 20th century, even the second phase owner, John B. Hower, of the then Akron- Selle Co. contributed with his own patents, the liquid gauge. Manufacturing for the transportation industry continued on the S. High Street site until in 1997 the Akron-Selle Gear Company left the complex, over a century after the original facility was built in 1887.

The Selle Gear Co. building is significant under Criterion C, for being a representative industrial building type of the Gilded Age of Akron, with stylistic features of the Romanesque Revival Style. Also, the Selle Gear Company building complex reflects the evolution of an industrial building type from the second half of the 19th century, as the "Expanded Mill" form to the "Single-level Factory" form of the early and mid- 20th century. The plant's engineering is also significant because it reflects the evolution of the construction and materials technology for industrial buildings from the end of the 19th century to mid-20th century, expressed in its structural system, materials and design. It evolved from wood frame masonry structure to brick, steel and glass wall structures, responding to the increased demand for large spans with the single and double-strut trusses, steel camel back arched tension cord trusses, fireproof reinforced concrete and Howe steel trusses.

Industrial and transportation development in South Akron in the 19th and 20th century.

The Selle Gear Company is located in the city of Akron, in what was formerly known as South Akron, established by Simon Perkins in 1825 as a canal town. Perkins was the owner of large tracts of land, a land agent and surveyor of the newly established Connecticut of the Western Reserve. He saw opportunities that the new canal would bring to the area and laid out the new village of Akron in a grid pattern with 300 lots. The intersection of Main and Exchange Streets became the heart of the village. The future Selle Gear Company, established after the Civil War, would first be situated in a new building on State Street, 3 blocks NW of this intersection. Later the factory was relocated in another new building about 4 blocks SE from Main and Exchange Streets, on Selle St. (formerly E. Chestnut St.) between S. High St. and S. Broadway St.

The successful completion of the canal from Cleveland to Akron in 1832, established the foundation for economic growth in Akron. At first the new village did not develop an industrial base, because it lacked the concentration of locks for the necessary water power, that, for example, the Village of Cascade or North Akron, established around 1832 had available. The 1825 Village of Akron did not progress economically beyond the regular canal traffic activity. Farmers would deliver their grain to towns more conveniently located, for example to the town of Clinton, a few miles to the South. Therefore, Perkins became instrumental in promoting the development

**United States Department of the Interior
National Park Service**

**NATIONAL REGISTER OF HISTORIC PLACES
CONTINUATION SHEET**

Section number **8**
Selle Gear Company
Summit County, Ohio

Page 2

of the Cascade Locks, along the Ohio & Erie Canal in the Cascade Village, a short distance to the North. South Akron had most of its SE section occupied by two water storage basins which were needed to operate the locks. One was the Upper Basin, which received its water from Summit Lake and was situated to the west of the Canal, the larger Lower Basin was situated to the east. Most of this land was deeded by Perkins to the State of Ohio as an incentive to invest in the construction of the Canal. The Selle Building Complex site is partially located today in the flood plain of the former Lower Basin.

By 1836, South and North Akron decided to join forces and petition the State legislature for a Town Charter. At that time their total population was 1,343 inhabitants.

During the canal era, South Akron became the place where the import and sale of merchandise occurred, as well as the shipment of produce and other goods. North Akron, in contrast, became the center of manufacturing and commercial resources. However, South Akron also became known for its construction of canal boats, the first industry of Akron. The first canal boat, the "State of Ohio" was built at the Lower Basin shipyards, and in 1827 took the official inaugural maiden voyage to Cleveland on the first finished section of the canal. Boat construction and canal boat activities became the principal manufacturing activities of South Akron. These canal related industries were surrounded by large residential neighborhoods providing housing for their workers, which continued to exist even after the Civil War, when the city started to change.

In 1842, when the Pennsylvania & Ohio Canal, was built to the east of the Ohio & Erie Canal, Akron become one of the most prominent Canal towns in Ohio. The canals brought growth and success to Akron and the region, but the arrival of the railroad in 1852 overshadowed this success and gradually caused the decline of the of the canals traffic.

Still, the existence of canal water combined with improving transportation systems brought new industries to Akron. These new industries settled along the canal, as well as along the new railroad tracks.

After the arrival of the railroad new industries developed, for example using local deposits of clay from Mogadore, Springfield and Tallmadge, the first stoneware factory on Main Street between Center and State Street, towards the north of South Akron. Furthermore, the transportation of local coal by rail and water powered the steam engines of the emerging power plants of the new industries; the production of oatmeal for feeding the Civil War troops manufactured by Ferdinand Schummacher, and the manufacturing of a variety of products at many other grain mills kept Akron and the regional economy alive. This economic boom swelled Akron's population to more than 5,000 prompting its incorporation in 1865 as a city.

Akron as a Great Manufacturing Center after the Civil War.

The railroad supported the establishment of new industries, like the Aultman, Miller & Co. formerly the Buckeye Mower & Reaper Works, manufacturers of agricultural implements, the Whitman Miles & Co. Knife Works, situated at the intersection of E. Exchange Street and the Akron Rolling Mill, west of the rail yards and south east of the Selle Gear Company's future site. Akron had become a national leader in the production of the mowers and reapers.

An elevated narrow gauge line of the Brewster Coal Rail Road company also delivered coal to the SE of the lower basin to their coal yards for loading on to the canal boats. The coal was also distributed to the Rolling Mills, the Diamond Match Company and Brewster built a spur line directly to the Match Company. Brewster also delivered coal to industries outside of Akron shipping 60,000 tons per year to Cleveland. This rail line touched the SW corner of the future Selle property site, following Wolf Run Creek to the Lower Basin. The Brewster coal rail line played a significant role in the industrial development of Akron, as well as the Atlantic & Great Western Railroad and the Cleveland, Mt. Vernon & Columbus Railroad which were well established by 1874 on the east side of the future home of the Selle Gear Co.

**United States Department of the Interior
National Park Service**

**NATIONAL REGISTER OF HISTORIC PLACES
CONTINUATION SHEET**

Section number 8
Selle Gear Company
Summit County, Ohio

Page 3

The Akron Rolling Mills was one of the most significant industries emerging in South Akron after the Civil War. It produced the metal for the growing machinery manufacturing industry in Akron, like harvesting machines produced by the Buckeye Works and Seiberling's Excelsior Works with coal as its main raw material, the plant was strategically located between Brewster Coal's Rail Line and the A&GW RR, on S. Broadway Street which the City of Akron closed at the owner's request in 1866. The site was abutting the SE corner of the unoccupied future Selle property.

By 1870, Akron's population had increased to 10,000 from 3,500 in 1860. Belching smokestacks were the sign of a very busy, exciting manufacturing town. At that time Akron was a town coming out of its canal era and relying more on the railroad. In 1872, around the basins, new industries included a brick mill was the first paper company manufacturing sacks for flour and cereals, produced by the flour mills, at the end of W. Exchange St. north of the Canal's Lower Basin and another group of industries on the east side of the Upper Basin, the Rubber Factory, the Chain Factory and the Barber Match Company built in 1871.

In 1880, a few years before the construction of the Selle Gear Co., the A&GW RR changed hands and became the NYPANO. The new railroad owners also purchased the Brewster coal rail line during this the time of great railroad mergers. The Ohio & Erie Canal remained open for the use of its water by the industries and local canal transportation of goods, but the Pennsylvania & Ohio canal was closed in 1884.

Establishment of Selle Gear Co.

Selle Gear Company is associated through its history from its founding with the railroad, the canal legacy era of c.1863-1913 and the post-canal era of 1913-1950. In 1885, Ferdinand Selle, who emigrated from Germany to America in 1852, came to Akron from Detroit, Wayne County, Michigan, to look for investors for manufacturing carriage hardware on the purported advise of Cleveland investors who already owned a portion of his patents. He was an inventor who already in January of 1883 received patents for vehicle hardware, like the improvement to the Wagon Platform Gearing, a device for steering. Half interest on the patent was sold in August of 1883 to J.M. Hamill Esq. from Cleveland, Ohio. Ferdinand Selle's invention immediately caught the eye of the local manufacturers and investors who were always eager for new ideas that would help the industrial development of Akron. Some of the same investors who helped Goodrich establish himself more than a decade earlier, Crouse, the president of the Buckeye Works, Mower and Reaper Co., and the Seiberlings, owners of the Empire Reaper and Mower Works and the new Seiberling Milling Co., supported Ferdinand Selle's ideas. Later, Selle held patents for a wide variety of platform wagon gears. His interest in transportation did not end with the Selle Gear Co. In 1889 he became the proprietor of the Akron Cart Works, after leaving Selle 1889, which he held later in partnership with his son until his death around 1920.

The Selle Gear Company's incorporation papers were filed on September 30, 1885 and approved by the Secretary of State on October 1, 1885. The incorporating officers were Edwin D. Myers, a printer and partner of the *Akron City Times*, Fred G. Tarbell, L. Markham, Ferdinand Selle and J. M. Beck, who migrated from Selb, Bavaria, Germany and owner of the Kubler & Beck Varnish Works. They started with a capital of \$25,000. The purpose of the corporation to be formed, according to the incorporation document, was "...to manufacture, purchase and deal in Specialties in Carriage Hardware of every description, and material of the Same...". The creation of the company reflected the new trend of joint ventures and capital interests which contributed to increase the level of success and prosperity of the industry in Akron. The Selle Gear Co. was viewed as a good investment, as its rapid growth proved.

After the incorporation of the company, manufacturing began first at a plant on West State Street, in South Akron, as shown on the Sanborn map of 1886. The new plant was situated less than half a block east of the Ohio & Erie Canal, between the Henninger Factory, next to the canal, and the Kubler & Beck Varnish Works to the east. Their manufacturing took place in a two story brick building with one story additions in the rear and a one story warehouse on the property. The steam power was obtained through a pipe connection to the Henninger Bartlett Planing Mill & Sash Door and Blind Factory next to the canal. The first floor had the wood shop

United States Department of the Interior
National Park Service

NATIONAL REGISTER OF HISTORIC PLACES
CONTINUATION SHEET

Section number **8**
Selle Gear Company
Summit County, Ohio

Page 4

with sawing and planing activities. On the second floor were the machine shops and the japan oven where japaning took place. One of the additions also had a wood shop and a machine shop, but the wood frame T-addition was where the blacksmith shop was located with an attached iron room. The first president of the Selle Gear Company on West State St. was Charles W. Seiberling and Ferdinand Selle was the superintendent.

After a successful beginning, the Selle Gear Company restructured in 1886, and proposed to increase its working capital and brought in a number of new directors. In March of 1887, the *Summit County Beacon*, reported in an extensive article about *Industries thriving in Akron* in general and Selle Gear in particular:

"...Their trend extends all over the United States, they having recently shipped a large order (300 gears) to San Francisco, California...This company is now the largest exclusive manufacturer of gears in this country, making gears for heavy work up to seven tons, and also for buggies. It will not be long before they will be obliged to build a larger factory, as they cannot keep up with their orders in their present quarters."

A few months later, during the summer of 1887, a new building complex was erected. In November of 1887 the *Summit County Beacon* reported in their news about the new structures in Akron's real estate: "...; the Selle Gear Co. has put grand new works;...". In October 1887, the company increased their capital stock to \$100,000. The new board of directors had a new president, A.L. Conger, also president of the Akron Steam Forge Company, George W. Crouse, vice-president, with Buckeye Works, William C. Parsons, secretary, who also was an officer of the Aultman, Miller Co, Buckeye Works, and Ferdinand Selle continued as superintendent.

The Selle Gear Company purchased the present site from Emily Ingersoll and J. A. Ingersoll from Chicago, Cook County, for \$5,000. Emily was the daughter of Capt. Richard Howe who was the resident engineer of the Ohio & Erie Canal supervising the construction of the canal from Cleveland to Massillon. He was also in charge of the survey and location of the Canal. The original site was approximately 2.7 acres, part of Lot No. 2 in tract No. 8 which also included Lots 269, 268 and half of lot 267, formerly in Portage Township, but now situated in Summit County. It was bounded on the north by East Chestnut (today Selle Street), to the east by South Broadway Street and to the west by South High Street. Today, with 3.24 acres, the property is slightly larger and zoned industrial.

The Selle Gear Company site was originally part of a steep rolling terrain, sloping from north to south. It was situated on the southeast corner of South Akron's grid planned city, on the flood plain of the lower basin, where water fed by Wolf Run Creek was stored for the operation of the Ohio Erie Canal locks. The Lower Basin, 10' below the summit level, connected with the canal below lock number 1, and was situated east of the upper basin in close proximity to the rubber industry's pioneer, B.F. Goodrich's factory complex. Today, this complex adaptively re-used into offices called Canal Way can be seen from the west and south west side of the Selle Gear Complex. Therefore, when the Selle Gear Co. was built in 1887, part of the building site was a swamp which was partially filled, according to the 1901-1902 addition specifications of architect F.O.Weary's: "... depth of six or eight feet, with cinders, which have become thoroughly settled and packed for years, upon which this new structure will rest...".

The company continued to grow, with more of Ferdinand Selle's and other inventor's related to wagon transportation hardware. (See Additional Documentation for Patent List). In 1889, a publication titled *"Leading manufacturers and merchants of the city of Cleveland and environs. A half century's of progress. 1836-1886; including the representative houses of the city of Akron"* published in New York, by the International Publishing Co. included the Selle Gear Company as one of the leaders in manufacturing with the following description:

"The Selle Gear Company, Sole Manufacturers of Selle's Patent Platform and Combination Wagon Gears, and of the Patent Crystal Hub Bands,- The Selle Gear Company, which, although a comparatively recent addition to the industrial institutions of Akron, now takes rank as the largest manufactory in the

**United States Department of the Interior
National Park Service**

**NATIONAL REGISTER OF HISTORIC PLACES
CONTINUATION SHEET**

Section number **8**
Selle Gear Company
Summit County, Ohio

Page 5

United States devoted exclusively to the production of platform, truck, omnibus, and combination gears....They are made from the best selected materials, on new and improved principles, and combine various points of practical excellence that give them a commanding position in the market....The house is in every way a representative one, and the officers, personally, are among the most progressive citizens of Akron."

By 1887, Ferdinand Selle sold his half ownership of his 1883 Wagon Platform Gear patent, to Edwin A. Akers of Cleveland, Ohio and Lucius C. Miles, of Akron, brother in law of Charles Seiberling, and left the Selle Gear Company in 1889 to establish his own company, the Akron Cart Works, manufacturing road carts, located not far away from Selle (a block and a half to the north), on 376 (806) S. Broadway Street, in a three story building behind a dwelling facing Wheeler Lane. Ferdinand wanted to go back to design and build the whole cart, not just the hardware. In the local directory, he advertised the Selle's Road Cart, which was represented by an elegant design as, "This cart is very convenient, strongly built, neat and graceful in appearance....The front of the body on this cart is hung on Selle's Truss Spring, which takes up all horse motion. The long Half Elliptic Spring is hung in Adjustable Swinging Hangers. Riding quality equal to a first-class buggy or carriage." Ferdinand Selle continued to be an inventor with great artistic talent as well. In 1899 his firm was known as Akron Wagon Works and his son Frank worked for him. In 1900, his wagon manufacturing business was listed under Ferdinand Selle, Wagon Manufacturer. In 1903, he moved his business to 28 W. Exchange St., a few blocks west from his house and his son continued to work on the S. Broadway address. By 1907, he formed a partnership with his son and the business was called F. Selle and Son. In 1914, they became also "distributors" of "The Grant"on of the new automobile lines, besides manufacturing wagons, but it lasted only for a year. The advances of car manufacturing put them out of business in 1918. Ferdinand Selle died in c.1921. The site of the old Akron Cart Works on S. Broadway Street was vacant in 1922 and the buildings were demolished by 1930 at the time when the Time- Press building, the future home of the Akron Beacon Journal was built on that block. Today, this site is part of the Akron Beacon Journal complex occupied by offices, warehouses and parking structures.

The new Selle Gear Co. 1887 headquarters on S. High Street were twice the size of their former home on West State Street but quickly proved to be too small. Several additions followed at the turn of the century. First, in 1901, a one story addition was added to the blacksmith shop and it was followed by two other additions in 1902 to the south (**Photo 30**), designed by prominent Akron architect Frank O. Weary. The same architect had also designed the Carroll County Courthouse and the Akron Carnegie Library (1904). Weary's additions to the original Selle Building were contracted for the amount of \$2,049 by the Hankey Lumber Co. of Akron and for \$1,189 by the H. H. Henninger Co.

The Selle Gear Company and the Akron Gear Company Mergers

In 1903 the Selle Gear Company changed its name after a merger with Akron Gear from the Akron Wood Working Company, and became known as the Akron-Selle Company. The officers of Selle before the merger were George Crouse, president, Frank M. Atterholt, vice president, and William C. Parsons, secretary, almost the original officers from the founding years of the Selle Company. The new company, the Akron-Selle Company, had M. Otis Hower as its new president, F.M. Atterholt, vice-president, and E.R. Held treasurer, and had a capital of \$100,000. Mr. Hower, like Seiberling, Wilcox, Conger and Crouse, before him, came from a prominent Akron family with interests in manufacturing. Hower's family had first made their money in oatmeal with the Hower Company, part of the family of Akron's prominent industries. The Hower Company closed after merging with Schumacher Mills, Quaker Mills, and North Star Mills in 1891 to become the American Cereal Company, moving its headquarters to Chicago. This consortium became later known as Quaker Oats Company. As new economic trends were emerging in Akron which were defined by the expansion of the rubber industry, the Hower family decided to invest in construction and manufacturing, with the establishment of the Akron Gear & Wood Working Company. Hower also was a member of the Akron Board of Trade and was the director of the Akron Light, Heat and Power Company.

United States Department of the Interior
National Park Service

NATIONAL REGISTER OF HISTORIC PLACES
CONTINUATION SHEET

Section number **8**
Selle Gear Company
Summit County, Ohio

Page 6

This merger with Selle Gear, an older and established gear company, with a newer emerging company, the Akron Gear, the only other gear company in Akron, followed the merger trends of the turn of the century. The new company would continue to “*control patterns of over 600 styles and sizes of gears and will embrace a complete line of coach, hearse, ambulance, fire department and wagon gears of all kinds, and will be the largest independent plant in the country*”, announced the *Akron Beacon Journal* in November of 1903.

The new company soon added a four story brick annex to the north and a small addition to the south of the 1887 building, in c. 1907 (**Photo 31**). This was followed by a one story complex of two buildings in c.1918, and a one story fireproof addition in 1920, after the purchase of the Tanner Hower Manufacturing Co, manufacturers of Tanner Level Gauges and Metal Stamping in 1916. The expansion in the 20th century continued with a steel frame, one story brick and glass warehouse addition built in c. 1943 (**Photo 24**) for the production of metal stamping and assemblies for trucks, aircrafts, etc., contributing to the war effort. The Akron - Selle Company was to occupy this location until 1997, when it closed its stamping operations at S. High Street.

With the growth of the automobile industry, Akron became the nation's leading producer of tires. At the turn of the century the city was already home to Goodyear Tire and Rubber Co., the B. F. Goodrich Company, and the Diamond Rubber Company. At the same time, the new Akron-Selle Company was also quick to adapt to the new times. In its early days, the Selle Gear Company manufactured platform wagon gears, hub caps and wagon reaches. In 1904, the company was described as making wagon gears, in 1906 they advertised themselves as manufacturers of wagons and trucks, and providing “*tire setting while you wait*”, a rubber industry product. By 1916 they did “*auto vehicle and truck specialties and repair work*”. After WW1, in 1919 their advertisement in the local directory mentioned “*Truck bodies built to order. Automobile trimming, painting and repairing*”. The manufacturing of parts for the carriage industry had moved on to the manufacturing of parts serving the automotive industry, during Akron's Magic Years, when the largest industrial expansion of the rubber tire industry occurred, as well as Akron's population.

Akron-Selle Co. had also found a niche in the manufacturing in the automotive parts industry, like apparatuses for liquid storage and various types of tank gauges that would indicate fluid level. Some of these devices were being made specifically for automobiles as early as 1912. Their production increased when in 1914 Akron-Selle acquired the Tanner-Hower Manufacturing Co. The company held a large amount of patents for a wide variety of liquid gauges, the company's main development interest in the late teens and early twenties. (See Additional Information for the list of some patents).

By the end of the 1920's, Akron-Selle advertised “*Automobile Body and Fender Repairing. Truck Bodies Built to Order. Automobile Trimming. Welded Steel Rings and Bands and Steel Stampings.*” In 1929, Akron-Selle discontinued the manufacturing of truck bodies. They entered metal stamping technology which defined their specialty until the end of the 20th century. By 1940, with a capital of \$200,000, their metal stamping production was well established. They also included Arc Welding, Spot Welding, Dies, Tools Jigs, Welded Steel, Rings and Bands and Blacksmiths. At the beginning of WWII, Akron - Selle was struggling, like many firms affected by the Depression Years. By mid-1942, the war production program shifted into high gear, like in the Magic Years of 1915-1921 that marked Akron's most significant economic growth, and Akron-Selle invested in new stamping machines and a new building addition to house them, especially after the tornado of 1943 destroyed its large 1887 one story manufacturing blacksmith wing. Selle then and discontinued manufacturing rings and bands and put all its capital investment into stamping machines. Stamping machines became very large, and therefore the new large steel structure building housed the new machinery. Akron-Selle also became part of the war economic boom and temporarily improved its economic situation. During the war they had 150 workers making military parts (*Sunday Beacon Magazine, July 5, 1998*). But after the war, it never completely recovered to the levels of significant growth occurred before the depression years. During WWII, Akron-Selle investment capital was reduced to \$50,000. After 1951, Akron-Selle manufactured metal stamping parts for trucks, tractors, automobiles and aircrafts. It slowly moved to manufacturing of stamping parts for consumer goods, like refrigerators, washing machines and military ordnance parts for companies all over the United States. Although they continued to produce parts for the transportation industry they gradually increased production of consumer goods which were in high demand by the growth of new communities developed for the returning GI's. The stamping production continued at the High Street

**United States Department of the Interior
National Park Service**

**NATIONAL REGISTER OF HISTORIC PLACES
CONTINUATION SHEET**

Section number 8
Selle Gear Company
Summit County, Ohio

Page 7

site until 1997 with a workforce down to 25 employees. The main offices moved out to Bartges St. in 1995, a few blocks south. By 1998 the Selle complex was put on the market. Still owned by the Hower family it was sold in 2003 to a group of investors.

Architectural Significance

The 1887 structure represents the industrial architecture of the end of the 19th century, when electricity and other power sources, existing building technology, fireproofing and manufacturing considerations defined the initial linear layout of the complex. These conditions created the search of new sites for industrial buildings along rail networks and other sources of power encountered in the emerging cities of the 19th century.

The replacement of water power by steam did not dramatically change the form of early industrial buildings. The linear form still remained, but it increased in size due to the complexity of production during the Second Industrial Revolution. The reliable steam power source facilitated the operation at many different structures on the same site. Also this new power source, required a separate structure, the powerhouse, for power generation. The Selle Gear Co. complex represents these changes.

Electricity was the next power source which contributed to the change of form and massing of the Selle complex seen in the almost square forms of the new additions of c.1918, 1920 and c.1943. It was the beginning of a new trend, the one story ground level plan, the single level factory following the dominant multistory mill/factory of the 19th century. This new form was based on material handling, instead of being determined by distribution of power by shafts.

The evolution of the Selle Gear complex is significant, because it also represents the evolution of window openings in industrial buildings, which is related to the desire for more natural lighting and the related new construction technology. The fenestration went from widely separated single windows to fully glazed bays and different types of roof openings for improved illumination. These changes became feasible when construction technology evolved from load bearing walls to masonry pier construction and later to steel-framed structural systems. The Selle Complex expresses this transition with its 1887 system of bearing walls and pier construction, and ending with a c.1943 steel frame. This building brought a maximum height, an expansive free floor and maximum glazing surfaces. Later this led to the curtain wall system of the 1950's. **(Historic Photo 3)** The new height was also needed to accommodate the larger manufacturing machines like the Bliss DB Crank 500 **(Historic Photo 2)**.

The Selle Gear complex is also important because it reflects the evolution of the different methods of fireproofing used through its history. The first attempts of fire-resistant construction were achieved by "slow wood burning construction", consisting of a structure of large timbers with heavy wooden floors and ceilings, and masonry walls. It incorporated another recommendation by the fire insurance companies: no furring and exposed brick walls in order to avoid the creation of any air space. (Gilbert, Christina, *"THE FORM AND AESTHETICS OF EARLY AMERICAN INDUSTRIAL BUILDINGS"* Master Thesis, Kent State University 1991). The original 1887 building represents this method of construction, together with the 1901, 1902 additions and the c.1907 addition and annex. By 1920, the first fireproof addition was built in the Selle complex using reinforced concrete and steel. Between 1907 and 1916, an automatic sprinkling system was introduced throughout the whole Akron - Selle building complex. Also new architectural forms, like the flat roof were adopted, because at that time flat roofs were considered less of a fire hazard. The c.1907 annex was built with a flat roof. The rigidity of design and diminished stylistic ornamentation of industrial buildings was also the result of the guidelines created by the Fire Insurance Companies. It is also important to recognize in the Selle building, the structural evolution from the 1887 masonry load bearing walls with piers defining rhythmical bays and traditional heavy timber framing, typical of the late 19th century, to 1920's reinforced concrete and steel structure, and the 1943 full steel frame addition.

The Selle Gear Company Building is significant also as an 1887 factory representing the Romanesque Revival architecture in industrial buildings, defined by its wall pier system, corbelling, string courses and arched windows. It also represents, with its later growth, the new 20th century industrial architecture of simplification of the surface with the introduction of reinforced concrete and steel, and steel

United States Department of the Interior
National Park Service

NATIONAL REGISTER OF HISTORIC PLACES
CONTINUATION SHEET

Section number 8
Selle Gear Company
Summit County, Ohio

Page 8

and glass.

The Selle Gear Company complex is also architecturally significant because it represents through its growth different industrial building types built during the late 19th century to the mid- 20th century. The 1887 section, is the original Industrial Expanded Mill/Industrial Block, the result of the introduction of steam power, when a more complex form was adopted. It consisted of 4 stories of manufacturing with a freight elevator, where mainly assembly and distribution took place with some light manufacturing, a one story manufacturing (the former blacksmith shop) and the one story power plant with a 95' chimney. It was a new industrial building type where architectural ornamentation increased. At the turn of the century, a new type of industrial building, called the Daylight Factory, became popular. There were two different forms, the Layered and the Single Level Factory, where proportion and grid defined the new form created by new technology. The c.1907 annex, the c.1918 and 1920 additions, as well as the c.1943 addition represent this new type. The new technology of concrete and steel allowed the reach of greater heights and spans with light structural steel and large glazing surfaces supported by structural steel mullions with operable hopper window sections.

The disappearance, in the 1943 tornado, of most of the 1887 one story factory building to the north of the Selle complex where manufacturing of the wagon gears took place affected only in a minor fashion the physical integrity of the original building, because most of the complex with all its physical growth has remained almost intact. After the tornado damage of 1943, Akron-Selle erected the large steel structure building, not only as a replacement of the destroyed building but also to meet the manufacturing demands imposed by the war effort.

The setting of the Selle Gear Company building complex in Akron's former South Akron, in the heart of the industrial district, with its prominent chimney, 19th century gabled structure surrounded by new rehabilitation of former industrial buildings, like the Goodrich Co., two blocks away, and the railroad depots, creates the feeling of a unified historic vibrant industrial era that provides Akron with an identity, as a premier industrial town of the 19th and mid-20th centuries.

Historic Context

The Selle Gear Company had carefully chosen their location in 1887, so as to be central to the other industries, businesses and modes of transportation in Akron. Only two blocks away was the complex for the B. F. Goodrich Company and nearby were numerous other foundries and machine companies. The Selle building directly adjoined most of the main railroad lines of Akron, which included the New York & Pennsylvania, Akron and Chicago, and Cincinnati and Pennsylvania Railroads, stopping at one of the main terminals only a block and a half away from Selle, to the north of S. Broadway Street. The new Selle location facilitated the delivery of their manufacturing products and raw materials. In November 1906, the company, now known as the Akron-Selle Company (after the 1903 merger), contracted with the Erie Railroad Company to extend a line directly to their manufactory off S. Broadway Street.

Akron-Selle had a very successful start after the merger of the Akron Gear Company and the Selle Gear Company in 1903. The company won two gold medals and a silver medal at the Lewis and Clark Centennial Exposition of 1905 in Portland, Oregon. One gold medal award was for "wagon gears" and the other for "end gate irons". The silver medal was for "spring blocks". All medals were in the "Transportation" category. These medals were given to inventions of Ferdinand Selle.

During the centennial celebration of the founding of the city of Akron in 1925, the importance of the Akron-Selle Co. was recognized in the *Centennial History of Akron* as being well on its way to becoming "one of the largest manufacturing institutions of the city." The Selle Gear Company manufactured for the carriage industry in the 19th century and the Akron-Selle Company manufactured for the automobile industry in the 20th century. This industry made significant contributions to the broad patterns of our transportation history, contributing with technological advances through its innovations during the Second Industrial Revolution and to the development of new transportation systems in Akron and the Nation. The Akron-Selle building therefore stands as a testimony to Akron's as well as the nation's industrial past.

United States Department of the Interior
National Park Service

NATIONAL REGISTER OF HISTORIC PLACES
CONTINUATION SHEET

Section number 8
Selle Gear Company
Summit County, Ohio

Page 9

After WWII and the Korean War the fortunes of the Akron-Selle Company changed with those of Akron. Industries began leaving the city in the late 1960's as the predominant workforce shifted from blue collar to white collar. The rubber industry giants, Goodrich, Goodyear and Firestone (Bridgestone) started to diversify into new transportation technologies, among them materials, aviation and space industries. By the early 1990's most of the big rubber companies manufacturing operations had left the city. B. F. Goodrich went into the aerospace industry in 1961. Firestone was purchased by Bridgestone in 1988. Goodyear expanded world wide, and reduced its Akron ties, going into aerospace and polymer materials. Most of the tire manufacturing moved to cheaper production markets. The Akron-Selle Company, after the 1950's diversified their production, continued their metal stamping operation and manufactured for a wide variety of consumer industries. The company still shipped nationwide and cited its Akron location as being "in the best spot for economical shipping" in its brochures. However, ultimately this diversification and lack of a substantial capital investment, was not enough to save the Akron-Selle Company from its gradual decline. It stopped production during the 1990s.

Today, the Selle Gear Company building is one of the few remaining 19th century industrial buildings in South Akron. A few other industrial complexes are already adaptively reused, like the former Goodrich Rubber Co., a block away on S. Main Street (**Photo 32**). The Selle Gear Building was built during the construction boom of 1887, when Akron was considered one of the leading cities of Ohio with blazing furnaces according to the *Summit County Beacon* November 9, 1887. Among the industrial buildings built at that time were the addition for Akron Rubber Works, additions to the Schumacher Milling Co., additions to the Webster, Camp & Lane on North Main Street, additions to the Pflueger's Enterprise Works, a Gymnasium for Buchtel College (today the University of Akron), the Paige Bros. Block commercial Building Block on Main Street, two block commercial buildings on Howard Street, two new churches, a school and a new train depot. Affordable housing was being built in large numbers at \$100 each for the growing labor force. From all the above mentioned buildings from that period only the Selle Building is still standing.

There is another later industrial building still standing of Romanesque Revival architecture, the Akron Silver Plate Co. and Faultless Rubber Co. built in 1891 on Bluff Street towards North Akron. But there are many more structures of Selles' industrial type still standing built in the style of the 1907 brick addition, with flat roofs, large segmentally arched windows framed by bays with corbeled frieze. Among them is the Firestone Tire and Rubber Building on Schweitzer Ave. built in 1905, the Akron Grocery Company on E. Mill Street across Quaker Square, the Goodyear Plant No.1 Clock Towers built in 1920, the Hardware and Supply Co. building built in 1922, south of the Akron-Selle Company on S. High Street, and recently demolished to make way for the S. High Street Viaduct. The Firestone Factory No.1 and Clock Tower on S. Main Street was also built between 1910-1924 with the characteristic flat roof, brick walls, corbeling and bays defined by pilasters.

Selle is the only gabled Romanesque Revival style building still standing representing the early industrial past of Akron as a newly formed city after the Civil War. Together with being a world leader in the rubber industry, the beginnings of manufacturing for the transportation industry made Akron so significant in the early parts of the 20th century. The Selle Gear Co. building complex remains as a testimony to the growth of the city of Akron during the Gilded Age, the Progressive Era and the automotive development of the 20th century. It is the only industrial building from the city of Akron nominated to be listed on the National Register of Historic Places. The Selle is also the only industrial building of this style and type remaining in the industrial area of the city of Akron.

The Selle Gear Co. building is vacant today, but many sections of the complex have been maintained and slightly used until its recent sale, after more than 100 years under practically the same ownership. At the moment, some sections of the building complex are slowly obtaining a new life, by being adaptively reused as warehouses and offices.

Conclusion

The Selle Gear Complex represents the history of the growth of new manufacturing in Akron, after the Civil War which replaced the boat building industry and canal transportation economy. The former industrial complex is part of the remnant of the canal legacy. The Selle Gear Co. grew together with the rubber industry and was also supported by local investors, energetic entrepreneurs and creative

**United States Department of the Interior
National Park Service**

**NATIONAL REGISTER OF HISTORIC PLACES
CONTINUATION SHEET**

Section number 8
Selle Gear Company
Summit County, Ohio

Page 10

inventors. It is not a coincidence that Akron houses the Inventors Hall of Fame. Selle represents the broad patterns of Akron's industrial development in regards to the manufacturing of specialty goods related to the transportation industry, the carriages, trucks, automobiles and military needs. The growth and evolution of Selle Gear as an industrial building type reflects physically Akron's industrial development. The Akron-Selle Co. represents also the industrial architecture of Akron during the Gilded Age and its Magic Years in the 20th century. One can read the evolution of the industrial history of Akron in the Selle's buildings built in 1887, the 1900's, the 1910's and the 1940's. The Selle Gear Co. building complex is part of the broad pattern of Akron's, Ohio's and the Nation's industrial history in manufacturing.

The Selle Gear Co. industrial building remains as one of the few examples of Romanesque Revival architecture used by industrial buildings in the 19th century, and its evolution to the more utilitarian, functional building represents the form follows function preamble of modern architecture.

The 1943 addition was important because it became part of the WWII effort and contributed at the same time to Akron's Selle recovery from the depression years. Unfortunately, this last building also marks the beginning of the decline of the Akron-Selle Company in the 20th century. The period of significance (criterion A), when Selle as a manufacturing entity was still contributing to the city's industrial and economic development, ends, 50 years ago. At that time Selle's production was still near capacity thanks to the Korean War.

United States Department of the Interior
National Park Service

**NATIONAL REGISTER OF HISTORIC PLACES
CONTINUATION SHEET**

Section number 9 Major Bibliographical References
Selle Gear Company
Summit County, Ohio

page 1

-
- "Akron Architecture." *Akron Daily Beacon-Saturday Supplement*. July 30, 1887.
- "Akron-Selle does it all." Brochure for The Akron-Selle Company, c. 1950.
- "Akron Still Booming. Brisk Business in Building." *The Summit County Beacon*. November 9, 1887.
- "Antoine Demars from Springwells (Detroit) Michigan." www.jenforum.org/demars/messages/132.html
- Atlas and Industrial Geography of Summit County, Ohio*. The Rectigraph Abstract & Title Company: Akron, 1910.
- "A Gear Combination" *Akron Beacon Journal*. November 23, 1903.
- Bergeron, Louis and Maiullari-Pontois, Maria Teresa, "The Factory Architecture of Albert Kahn". www.architectureweek.com
- Byard, Katie. "The Selle Co. Shifts Gears." *The Sunday Beacon Magazine*. July 5, 1998, p. 20.
- Combination Atlas Map of Summit County, Ohio*. Tackabury, Mead & Moffett: Philadelphia, 1874. p. 61
- Deed between Emily B. Ingersoll, James A. Ingersoll and The Selle Gear Co.*, July 25, 1887.
- Deed between The Selle Gear Co. and the Akron Selle Co.*, November 30, 1903.
- Deed between The Erie Land and Improvement Company and the Akron Selle Company*, March 1, 1905.
- Deed between the Akron Selle Co. and the Selle Generator Works, Ltd.*, February 28, 2003.
- Document Authorizing the Increase of the Working Capital of the Selle Gear Company*, dated January 2nd 1886. Manuscript from the Collection of the Selle Generator Works, Ltd.: Chambers, Murphy, and Burge, repository.
- Doyle, William B. *Centennial History of Summit County, Ohio and Representative Citizens*. Biographical Publishing Company: Chicago, 1908.
- Gieck, Jack. *A Photo Album of Ohio's Canal Era, 1825-1913*. The Kent State University Press: Kent, Ohio & London, England, 1988.
- Gilbert, Christina C., *The Form and Aesthetics of Early American Industrial Buildings. An Investigation of Housing Reuse Feasibility*. Master Thesis. Kent State University, Kent, Ohio, 1991.
- Gordon, Stephen C. *How to Complete the Ohio Historic Inventory*. Ohio Preservation Office & Ohio Historical Society: Columbus, 1992.
- Grismer, Karl H. *Akron and Summit County*. Summit County Historical Society: Akron, Ohio, 1954.
- "He Has Applied For Land." *Akron Beacon Journal*, December 23, 1903. High Beam Research. www.highbeam.com

United States Department of the Interior
National Park Service

**NATIONAL REGISTER OF HISTORIC PLACES
CONTINUATION SHEET**

Section number 9 Major Bibliographical References
**Selle Gear Company
Summit County, Ohio**

page 2

"How Industries Thrive in Akron." *The Summit County Beacon*, March 9, 1887.

Howe, Henry. *Historical Collection of Ohio, Volume II*. C. J. Krehbiel & Company: Cincinnati, 1900.

"Three Fragen ...Ihre Antworten" January 22, 2001. www.finnetrop.com/ihre_fragen.htm.

Incorporation Papers for the Selle Gear Company, dated September 30, 1885. Manuscript from the Collection of the Selle Generator Works, Ltd.: Chambers, Murphy, and Burge, repository.

Kidder, Frank, "The Architect's and Builder's Handbook", New York, John Wiley & Sons, Inc. 1921.

Knepper, George W. *Akron, City at the Summit*. Continental Heritage Press: Tulsa, 1981.

Lane, Samuel A. *Fifty Years and Over of Akron and Summit County*. Beacon Job Department: Akron, 1892.

Leading Manufacturers and merchants of the city of Cleveland and environs. A half century's progress. 1836-1886; including the representative houses of the city of Akron." New York. International Pub. Co. c.1886.

Lewis and Clark Centennial. Manuscript #1609. Oregon Historical Society, Portland, Oregon, repository.

N. H. Burch and Co., *The Akron City and Summit County Directory, 1887-1889*. The Werner Printing and Lithograph Company: Akron.

N. H. Burch and Co., *The Akron Official City Directory, 1899-1904, 1906-1909, 1911-1920, 1922, 1926-1928, 1930-1941-1948, 1950, 1960, 1980*

N. H. Burch and Co., *The Burch's Akron City Directory, 1997-1999, 2002-2004*. The Polk & Co. Publisher. Taylor, Michigan.

Nichols, Kenneth. *Yesterday's Akron*. E. A. Seemann Publishing, Inc.: Miami, FL., 1976.

Plat Book of the City of Akron, Ohio and Vicinity. G. M. Hopkins, Company: Philadelphia, 1915. p. 136-138.

"The Press Experts". www.metalist.com

"Remanufacturing. The Cost Effective Solution." www.blissclearingniagara.com

Sanborn Insurance Maps. Akron 1886, 1892, 1904, 1916, 1940, 1950.

"Two Gear Companies Combine." *Akron Beacon Journal*, November 16, 1903

Summit County Administration Bldg, Deeds.

Summit County Historical Society, "A Centennial History of Akron." The General Committee of the City's First Centennial Celebration, 1925.

United States Department of the Interior
National Park Service

NATIONAL REGISTER OF HISTORIC PLACES CONTINUATION SHEET

Section number 9 Major Bibliographical References
Selle Gear Company
Summit County, Ohio

page 3

Voucher from the Erie Railroad Company for an Extension of a Rail Line. November 30, 1906. Manuscript from the Collection of the Selle Generator Works, Ltd.: Chambers, Murphy and Burge, repository.

Weary, Frank O. *Specifications for a Two Story Brick Addition to the Selle Gear Factory, Akron, Ohio.* 1901. Manuscript from the Collection of the Selle Generator Works, Ltd.: Chambers, Murphy, and Burge, repository.

Weary, Frank O. *Specifications for the Building of an Addition to the Smith Shop of Selle Gear Works, Akron, Ohio.* 1901. Manuscript from the Collection of the Selle Generator Works, Ltd.: Chambers, Murphy, and Burge, repository.

University of Akron Archives, Tax Duplicates: 1885-1905.

**United States Department of the Interior
National Park Service**

NATIONAL REGISTER OF HISTORIC PLACES CONTINUATION SHEET

Section number 10 Geographical Data
**Selle Gear Company
Summit County, Ohio**

Page **1**

Verbal Boundary Description

The Selle Gear Building property is located on one parcel of land, being a part of Lot No. 2 in Tract No. 8, formerly a part of Portage Township, and now within the City of Akron, Summit County, Ohio. This parcel includes 4 vacated lots, 269, 268, 267 and 266, formerly on the south side of Chestnut Street, now known as Selle Street. The property was formerly owned by The Akron-Selle Company. It is located to the south of Selle Street, to the west of South Broadway, and to the east of South High Street. The property is bounded by the East Right of Way line of South High Street, the South Right of Way of Selle Street, the west Right of Way of South Broadway, and the North East corner of Block 1-1C, bordering the north property line of the Horning Wright Company, a concrete ready-mix and concrete construction company. The rectangular property is approximately 478 feet long and 299 feet wide. The parcel contains 3.247 acres.

Verbal Boundary Justification

The nomination property includes all the land historically owned by the Selle Gear Company.

**United States Department of the Interior
National Park Service**

**NATIONAL REGISTER OF HISTORIC PLACES
CONTINUATION SHEET**

PATENT LIST

Page 1

**Selle Gear Company
Summit County, Ohio**

1883. Wagon Platform Gearing. Patent by Ferdinand Selle from Detroit, Wayne County, Michigan. Half interest on the patent sold to J. M. Hamill Esq. from Cleveland, Ohio. One fourth sold to Edwin A. Akers of Cleveland, Ohio and Lucius C. Miles of Akron, Ohio in 1887.
1884. Vehicle Hub Cap. Patent by John G. Eberhard. Interest sold in 1884, to George F. Eberhart and Charles A. Akers and subsequently to the Cleveland Carriage Goods Co. Vehicle-wheel hub provided with a front piece of glass or porcelain in the place or ordinary plated metallic linings or caps, which easily tarnish and lose their luster.
1886. Wagon Reach. Patent by Ferdinand Selle. Improvements on Buggy and Wagon Reaches. It consists in the combination with any suitable wooden reach, of a metallic re-enforcing and strengthening rod or bar partially or completely embedded there in. Page 1 and Page 2.
1886. Vehicle Platform Gear. Patent by T. H. Holman of Newark, Licking County, Ohio. Platform gears for spring vehicles. It does away with the rear cross springs, and provide a safe, durable, and effective fastening for the ends of the springs. Page 1 and Page 2.
1888. End Gate. Patent by Ferdinand Selle of Akron, Summit Co., Ohio, assignor to the Selle Gear Company. Improvements of end gates for vehicles in which the mechanism for bracing the sides of the body for holding the end-gate closed and for holding the sides of the body from spreading while the end-gate is closed are arranged on the inside of the body, to the end that the parts are strong, convenient, and do not mar the finish or effect of the body from the outside.
1889. Anti Rattlers for Thill Couplings. Improvements. Sold to Selle Gear Co. by Charles Lee and Charley L. Lee from Burbank, Wayne Co. Ohio. The object patented is to provide a simple and inexpensive device applicable to the various sizes and styles of couplings whereby the shackles which connect the thills and axle are prevented from rattling and are held snugly in position, which device is capable of easy application and withdrawal from the coupling.
1896. Ball Bearing For Axles. Patent by T.H.Holman of Newark, Licking County, Ohio, assignor of one half to H.K. Johnson of Chicago, Illinois. Ball bearings for vehicle- wheels in order to reduce the friction between relatively- rotating parts.
1897. Fifth Wheel. Patent by William C. Parsons of Akron, Ohio, assignor to the Selle Gear Company. The invention relates to improvements in roller fifth-wheels for wagons, drays, carriages and kindred purposes.
1902. Indicator for tanks. Patent by Clark Johnson and Donald M. Cameron of Detroit, Michigan. Improvement in float-actuated indicators intended to show the quantity of liquid contained in the tank with which the indicators are connected.
1904. Clinker Catcher. Patent by Milton O. Hower, from Akron, Ohio. Device for removing from furnaces, fire-pots, clinkers, slate and anlagous non-consumable substances and for palcing therein and removing therefrom such objects as require to be heated, such as crucibles containing matter to be melted, articles to be annealed and other similar uses.
1907. Apparatus for Indicating the Depth of Liquid in a Vessel. Patent by Leonard Murphy from Dublin, Ireland. It determines the depth at a distance from the vessel by the pressure of air and gas introduced above the surface of an indicating liquid contained in a suitable gage reservoir.

**United States Department of the Interior
National Park Service**

**NATIONAL REGISTER OF HISTORIC PLACES
CONTINUATION SHEET**

PATENT LIST

Page 2

**Selle Gear Company
Summit County, Ohio**

1907. Automatic Gage. Patent by Phelps M. Freer, from Barberton, Ohio, assignor of two-fifths to Harold C. Parsons, from Akron, Ohio. Purchased by Perry Tanner in 1911. Invention related to improvements of automatic gages or indicators for use in indicating or registering the quantity of liquids in storage vessels.
1908. Indicator for Tanks. Patent by Julius B. Laursen, of Sorkness, North Dakota. The indicator is for use in connection with tanks for receiving gasoline, alcohol, or analogous liquids.
1908. Fluid Level Indicator. Patent by Morris Martin, of Boston, Massachusetts. Assignor of one-half to Boston Auto Gage Company of Boston, Massachusetts, a Corporation of Massachusetts. The invention is for the production of a magnetically controlled fluid level indicator. A bushing for holding the gage may be dispensed with the force of the magnet located within the tank acting through the non-magnetic metal of the tank to turn in unison with it a magnetic needle located outside the tank.
1909. Liquid Indicator. Patent by Edmund E. Hans of Minneapolis, Minnesota. The invention relates to improvements in indicators for measuring the height of liquids in a tank for use in connection with the gasoline tank of an automobile to enable the driver to determine at a glance the height of the gasoline in his tank.
1911. Tank Gauges. Patent by William Warden of Akron, Ohio, living in Ottawa, Ontario, in 1911. Improvement. Relates to gauges for liquid containing tanks and has particular reference to a gauge adapted for use with the fluid fuel containing tank of an automobile.
1912. Gage. Improvement. Patent by Harrison D. Flegel and Benjamin f. Flegel from Racine, Wisconsin. Purchased by Perry Tanner in 1912. Gages for use in the connection with the gasoline tanks of automobiles. This simple device would be applied to a regular gasoline tank which will accurately indicate the amount of liquid contained within the tank.
1912. Indicator for Liquid Containers. Patent by Frederick L. Pfahl, of Akron, Ohio. The invention provides and indicator with improved construction and arrangement of operating mechanism whereby the level of the liquid in the container will be accurately indicated.
1913. Water Gage. Patent by Francis W. Walraven and Charles E. Calkins, of Las Cascadas, Canal Zone. The water gage to be used for steam boilers, in order to provide a simple, cheap, and reliable device to replace the ordinary glass gage commonly used. This new gage should provide a reliable and safe means of visually indicating the water level in steam boilers of all descriptions.
1915. Gage for Liquid Containing Tanks. Patent by Perry E. Tanner of Akron, Ohio. This gage is a measuring device to determine the height of liquid in a closed tank with an exterior dial.
1916. Gage for Liquid Containing Tanks. Patent by Perry E. Tanner, of Akron, Ohio. The invention relates to gages for liquid containing tanks, whereby the height of the liquid in the tank is indicated upon a dial so as to be observed at a glance.
1917. Liquid Gage. Patent reissued by Harrison D. Flegel of Racine, Wisconsin, Assignor by Messe Assignments, to the Akron-Selle Co. Of Akron, Ohio, a Corporation of Ohio. This gage invention is for liquid containing tanks. It is a simple, economical and efficient gage, where all parts maybe made of rugged and lasting character without the need of delicate adjustments and frictionless bearings.

**United States Department of the Interior
National Park Service**

**NATIONAL REGISTER OF HISTORIC PLACES
CONTINUATION SHEET**

PATENT LIST

Page 3

**Selle Gear Company
Summit County, Ohio**

1917. Liquid Storage Apparatus. Patent by Lewis A. Mapel of St. Louis, Missouri, Assignor to Mechanical Development Company of Missouri, of St. Louis, Missouri, a corporation of Missouri. The invention relates to tanks or containers use for storing liquids. It provides a new way for indicating the level of the liquid stored in the tank.
1920. Depth Indicating Device. Patent by Edwin E. Huffman and Orph W. Cowgill, of St. Louis, Missouri. This invention is a tool for indicating the depth of liquid in containers, like, fuel tanks of automobiles.
1921. Depth Indicating Device. Patent by Horace W. King of Ann Arbor, Michigan. This invention for indicating the depths of liquids is exceedingly simple to construct allowing to be cheaply manufactured.
1921. Depth Indicating Device. Patent Horace W. King of Ann Arbor, Michigan. This invention is for determining the depths of liquids, but especially applicable for devices in which air under pressure is used to force a liquid from a tank, but with proper modification it may be used to indicate the depths of liquids not under pressure.
1921. Liquid Level Gage. Patent by Mattias O. Lundin of Los Angeles, California. This invention relates to gages of the character employed in indicating the level of liquid in a container, and the invention is especially applicable to indicate the level of liquid in a container at a distance from the sight glass.
1927. Liquid Gauge. Patent by John B. Hower and Joseph V. Zeller of Akron, Ohio, assignors to the Akron-Selle Company of Akron, Ohio, a Corporation of Ohio. This invention is particularly directed to an improved type of gauge for use in liquid containing tanks of all types, the principal object of the invention being the provision of an improved and simplified type of head for such a gauge.
1928. Liquid Gauge. Patent by John B. Hower and Joseph V. Zeller, of Akron, Ohio, assignors to the Akron-Selle Company, of Akron, Ohio, a corporation of Ohio. The invention is directed to an improved and simplified gauge of the tube type which may be manufactured at an extremely low cost.

United States Department of the Interior
National Park Service

NATIONAL REGISTER OF HISTORIC PLACES CONTINUATION SHEET

PATENT LIST
Selle Gear Company
Summit County, Ohio

(No Model.)

F. SELLE.
WAGON PLATFORM GEARING.

No. 270,254.

Patented Jan. 9, 1883.

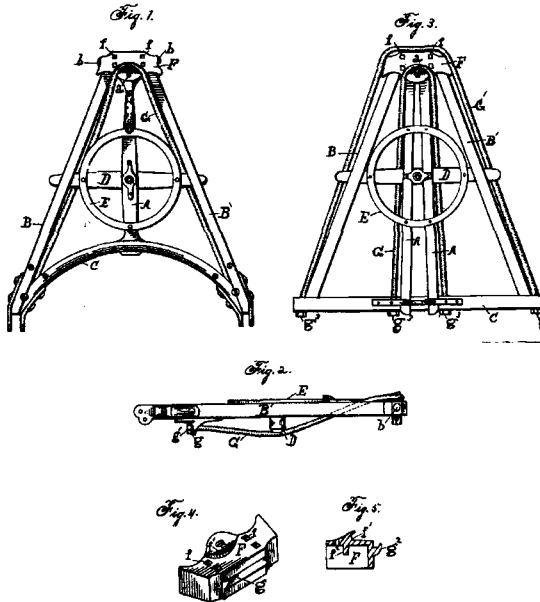

WITNESSES
Samuel Thomas
Steward Hosen

INVENTOR
Ferdinand Selle.
By W. W. Leggett.

Selle. Wagon Platform Gearing. 1883.

United States Department of the Interior
National Park Service

NATIONAL REGISTER OF HISTORIC PLACES
CONTINUATION SHEET

PATENT LIST
Selle Gear Company
Summit County, Ohio

(No Model.)

F. SELLE.
WAGON REACH.

2 Sheets—Sheet 1.

No. 346,325.

Patented July 27, 1886.

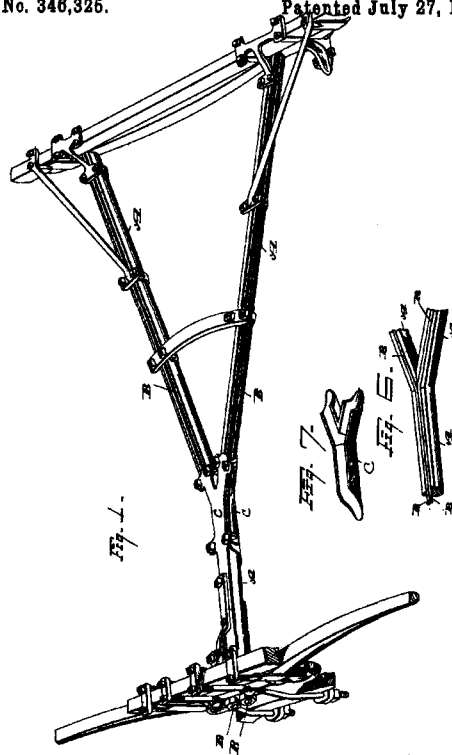

WITNESSES
M. M. Monroe
L. Hoover

INVENTOR
Ferdinand Selle
by *Robert E. Sargent*
Attorney at Law

A. PETERSON, Patent Artist, Washington, D. C.

United States Department of the Interior
National Park Service

NATIONAL REGISTER OF HISTORIC PLACES
CONTINUATION SHEET

PATENT LIST
Selle Gear Company
Summit County, Ohio

(No Model.)

2 Sheets—Sheet 2.

F. SELLE.
WAGON REACH.

No. 346,325.

Patented July 27, 1886.

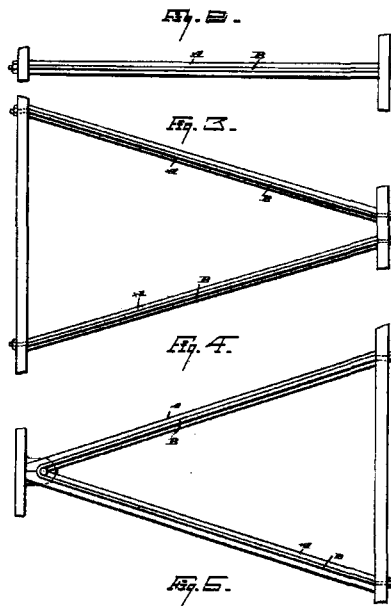

WITNESSES
Wm. M. Johnson
Geo. A. Brown

INVENTOR
Ferdinand Selle
 by *Ruggell & Suggitt*
 ATTORNEYS

U. S. PATENT OFFICE: WASHINGTON, D. C.

United States Department of the Interior
National Park Service

NATIONAL REGISTER OF HISTORIC PLACES
CONTINUATION SHEET

PATENT LIST
Selle Gear Company
Summit County, Ohio

(No Model.)

F. SELLE.
END GATE.

No. 388,002.

Patented Aug. 14, 1888.

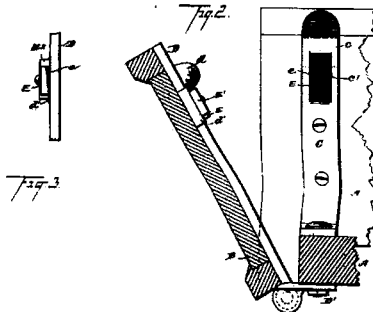
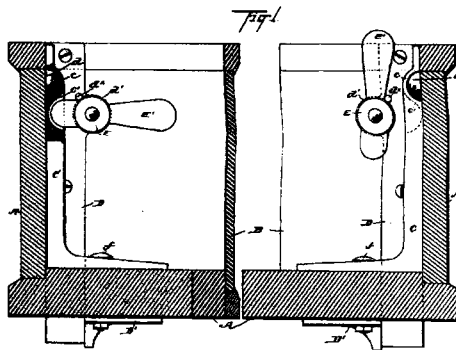

WITNESSES:
C. S. Amstutz
Geo. W. King

Ferdinand Selle INVENTOR.
Geo. Leggett Viggott ATTORNEY.

© PATENT PUBLIC OFFICE, WASHINGTON, D.C.

Selle. End Gate. 1888

United States Department of the Interior
National Park Service

NATIONAL REGISTER OF HISTORIC PLACES CONTINUATION SHEET

PATENT LIST
Selle Gear Company
Summit County, Ohio

P. E. TANNER.
GAGE FOR LIQUID CONTAINING TANKS.
APPLICATION FILED JUNE 18, 1914. Patented Feb. 23, 1915.
2 SHEETS-SHEET 1

1,129,837.

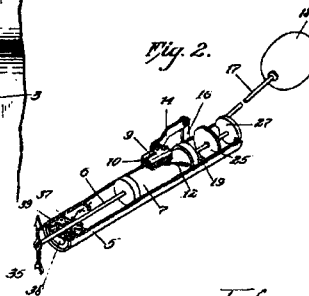
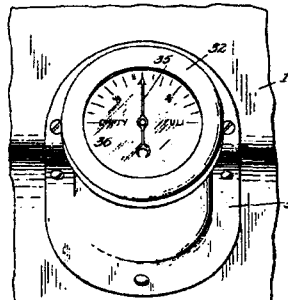
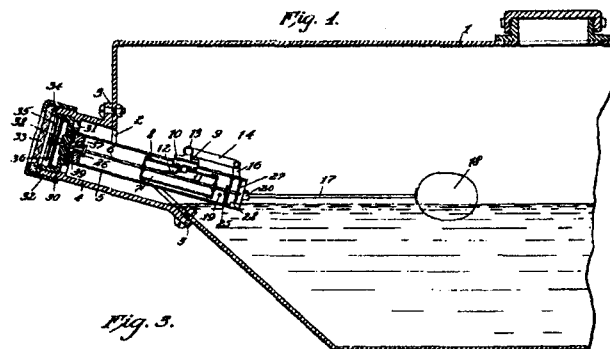

Witnesses:
R. C. Duck,
H. B. McKill

Inventor,
Perry E. Tanner
By Hull & Smith
attys.

THE MORGAN PETERSON CO. PRINTERS, WASHINGTON, D. C.

Tanner. Gage for Liquid Containing Tanks. 1915

United States Department of the Interior
National Park Service

NATIONAL REGISTER OF HISTORIC PLACES CONTINUATION SHEET

PATENT LIST
Selle Gear Company
Summit County, Ohio

Page 9

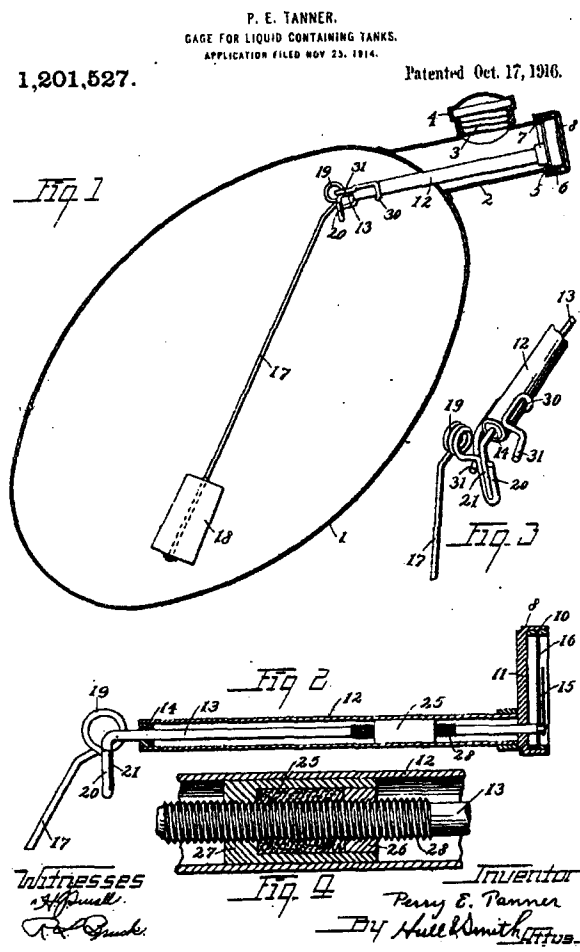

Tanner. Gage for Liquid Containing Tanks. 1916

United States Department of the Interior
National Park Service

NATIONAL REGISTER OF HISTORIC PLACES CONTINUATION SHEET

PATENT LIST
Selle Gear Company
Summit County, Ohio

Nov. 8, 1927.

J. B. HOWER ET AL
LIQUID GAUGE
Filed March 5, 1923

1,648,731

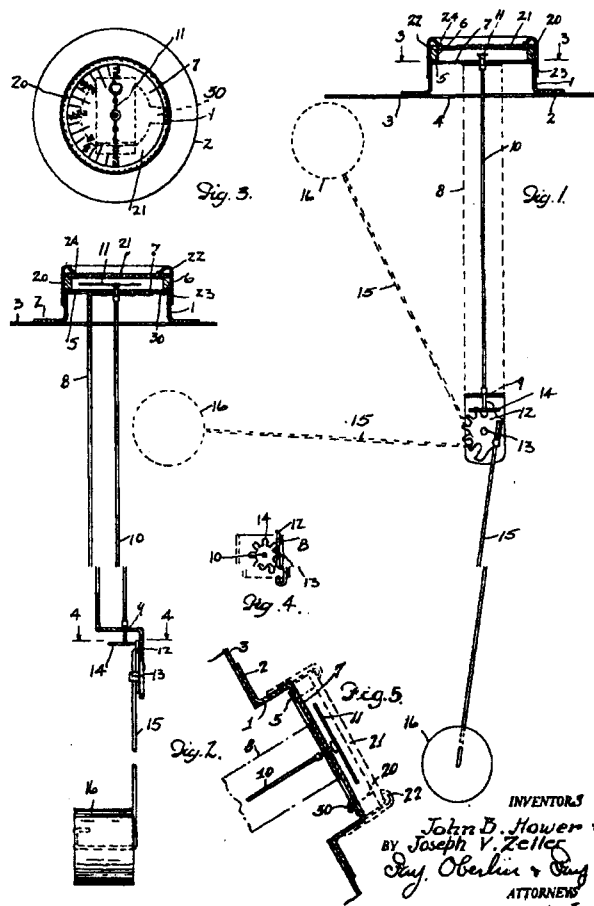

INVENTORS
John B. Hower &
Joseph V. Zeller
By Oberlin & Day
ATTORNEYS

J.Hower-Zeller. Liquid Gage. 1927

United States Department of the Interior
National Park Service

NATIONAL REGISTER OF HISTORIC PLACES CONTINUATION SHEET

PATENT LIST
Selle Gear Company
Summit County, Ohio

Page 11

July 24, 1928.

J. B. HOWER ET AL
LIQUID GAUGE
Filed March 5, 1923

1,678,513

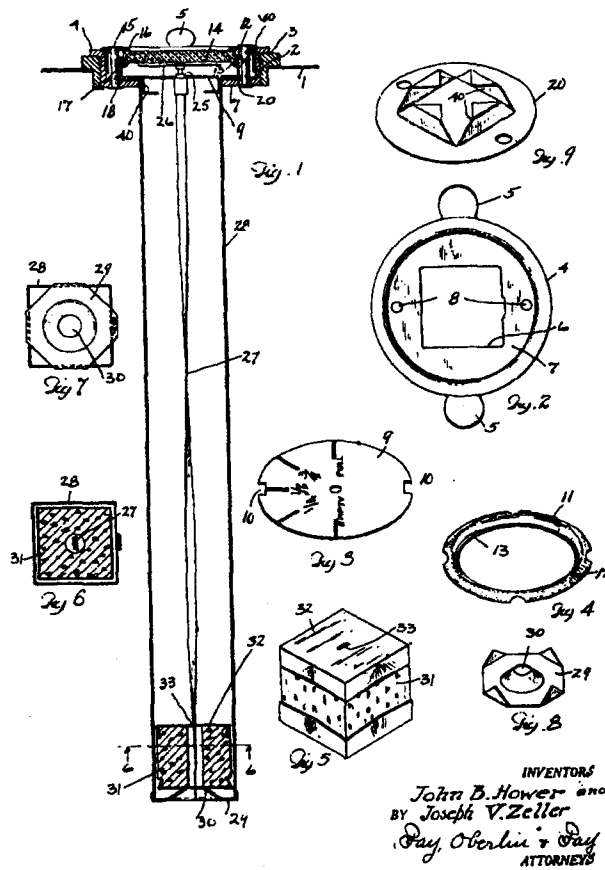

J.Hower-Zeller. Liquid Gage. 1928

**United States Department of the Interior
National Park Service**

**NATIONAL REGISTER OF HISTORIC PLACES
CONTINUATION SHEET**

**PHOTO LIST
Selle Gear Company
Summit County, Ohio**

page 1

-
1. West view of skyway. 1907 Building left. 1887 Building right.
 2. South West view of complex.
 3. South and West elevations of 1887 Building. South West View.
 4. West view of 1887 Building from parking lot at S. High Street.
 5. East gable end of 1887 Building. Old name. Facing S. Broadway Street.
 6. West gable end of 1887 Building. Old logo. Facing S. High Street.
 7. East door on Second Floor of 1887 Building. Facing S. Broadway Street.
 8. West view of former section of blacksmith shop of 1887 Building. Facing S. High Street.
 9. West elevation of 1887 Building's former blacksmith storage wing.
 10. Low gabled powerhouse of 1887 Building. 1901 and 1902 additions to the left. South elevation.
 11. Power plant chimney of 1887 Building. South elevation.
 12. East elevation at S. Broadway Street of 1887 Building (to the left) and c.1907 Building (to the right). Looking from the Northeast.
 13. Fourth floor bay of 1887 Building.
 14. Skyway connection to 1887 Building. East view.
 15. Corbelled cornice of 1907 Building. South elevation.
 16. Skyway between the third floors of Buildings 1887 and 1907. Looking West.
 17. North Elevation of Building 1887. Connecting skyway. Looking from S. Broadway Street.
 18. North and East elevations of c.1918 Building at the corner of S. Broadway and Selle streets. Former Goodrich Tire Co. in the background. Looking S.W.
 19. North elevation of 1920 fireproof building to the right of the c.1918 building on Selle St.
 20. Interior of c.1918 Building on S. Broadway and Selle streets. Warren steel truss roof.
 21. North elevation of c.1918 Building at the corner of S. Broadway and Selle streets.
 22. Interior of c.1918 Building facing S. High Street. Warren trusses and skylights.

**United States Department of the Interior
National Park Service**

**NATIONAL REGISTER OF HISTORIC PLACES
CONTINUATION SHEET**

PHOTO LIST

**Selle Gear Company
Summit County, Ohio**

page 2

-
23. Interior of 1920 Building, a fireproof concrete structure. Facing Selle St.
 24. North West corner of c.1943 Building at Selle and S. High streets.
 25. Courtyard entrance on S. High St. with c.1943 Building to the left, c.1918 Building in the center and c.1907 Building to the right.
 26. South elevation of Building c.1943 on S. High and Selle streets. View from the new S. High Street Viaduct.
 27. Interior of c.1943 Building . Looking NW towards Selle Street entrance.
 28. Interior of c. 1907 Building. Strut trussed beams on the 4th floor. Looking East.
 29. Interior of 1887 Building. Former machine room on the 4th floor.
 30. South Elevation of 1887 Building with one and two story shed roof 1901 and 1902 additions designed by Frank O. Weary left to the power plant.
 31. South and West elevation of c.1907 Building. Looking Northwest.
 32. Looking from dock rear entrance of c.1943 Building to the former Goodrich Rubber Co. complex on S. Main St.

Historic Photo List

- HP1. North elevation of 1887 Building. Looking from Northeast. Date c.1900
- HP2. Interior of c.1943 Building. Bliss DB Crank 500 Press machine. Date c.1950.
- HP3. South Elevation of the Akron-Selle Building Complex. Date 1958.
- HP4. Interior of 4th floor of 1887 Building. Machine Room. Looking NW. Peerless metal cutting saw machine in front. Date c. 1927
- HP5. Interior of 3rd floor of 1887 Building. Machine Room. Looking North. Date c. 1927
- HP6. Interior of 3rd floor of 1887 Building. Machine Room. Looking South. Date c. 1927.
- HP7. Interior of 3rd floor of 1887 Building. Machine Room. Looking East. Date c. 1927.
- HP8. Interior of 4th floor of 1887 Building. Machine Room. Looking Southeast. Date c. 1927.
- HP9. Interior of c. 1918 Building. N.E. corner facing Selle & S. Broadway streets. Large press room. Date c. 1927

**United States Department of the Interior
National Park Service**

**NATIONAL REGISTER OF HISTORIC PLACES
CONTINUATION SHEET**

**PHOTO LIST
Selle Gear Company
Summit County, Ohio**

page 3

HP10. Interior of c.1918 Building. S.E. corner facing S. Broadway St. Large Press room. Date c. 1927

HP11. Interior of c.1918 Building. N.W. corner view, facing Selle Street. Large press room. Date c.1927

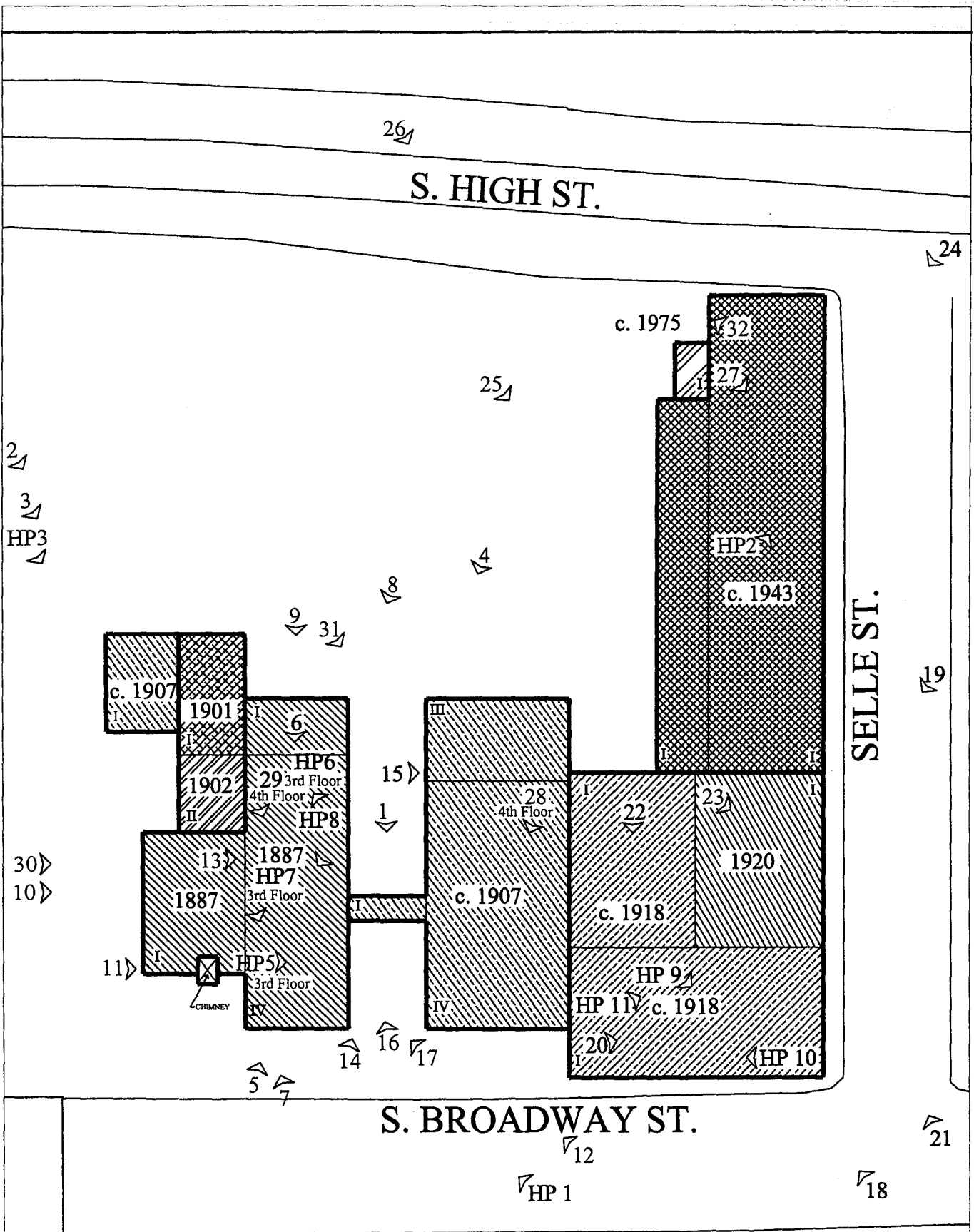

→ SELLE BUILDING PHOTO KEY
 SCALE: NTS

United States Department of the Interior
National Park Service

NATIONAL REGISTER OF HISTORIC PLACES CONTINUATION SHEET

MAPS
The Selle Gear Company
Summit County, Ohio



Future 1887 Site of the Selle Gear Co. Akron. 1882 Atlas

United States Department of the Interior
National Park Service

NATIONAL REGISTER OF HISTORIC PLACES
CONTINUATION SHEET

MAPS

The Selle Gear Company
Summit County, Ohio

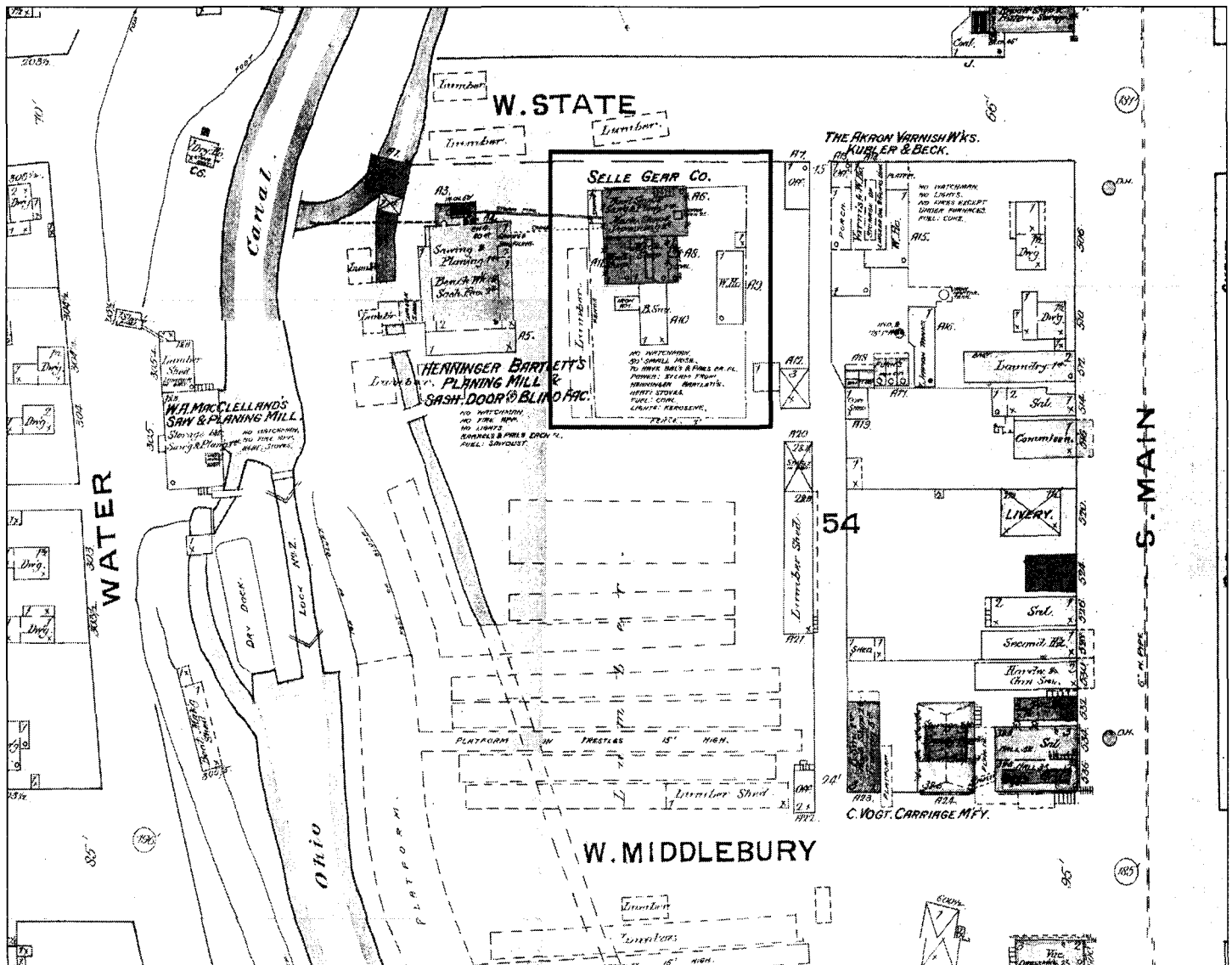

The Selle Gear Company – original location. Akron. Sanborn Map 1886

United States Department of the Interior
National Park Service

NATIONAL REGISTER OF HISTORIC PLACES CONTINUATION SHEET

MAPS
The Selle Gear Company
Summit County, Ohio

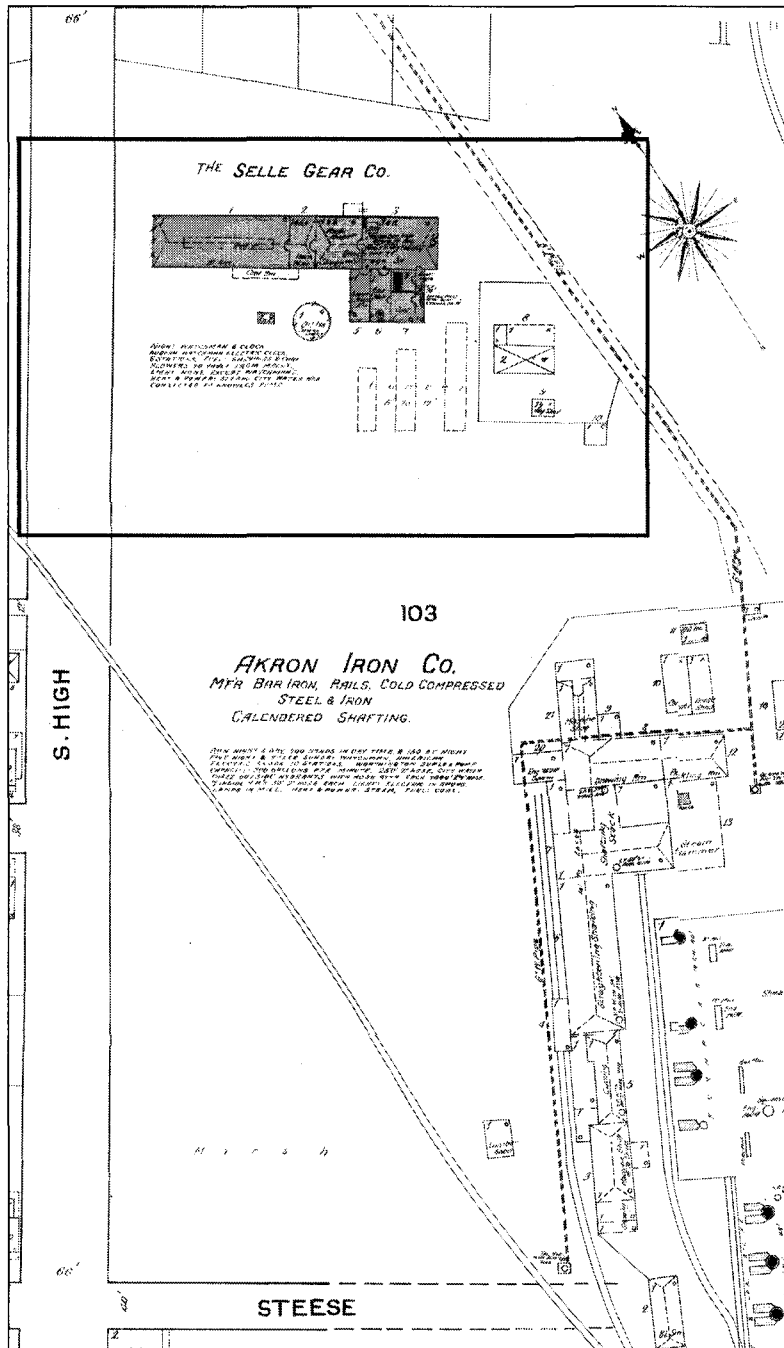

The Selle Gear Company - Surround. Akron. Sanborn Map 1892

United States Department of the Interior
National Park Service

NATIONAL REGISTER OF HISTORIC PLACES
CONTINUATION SHEET

MAPS
The Selle Gear Company
Summit County, Ohio

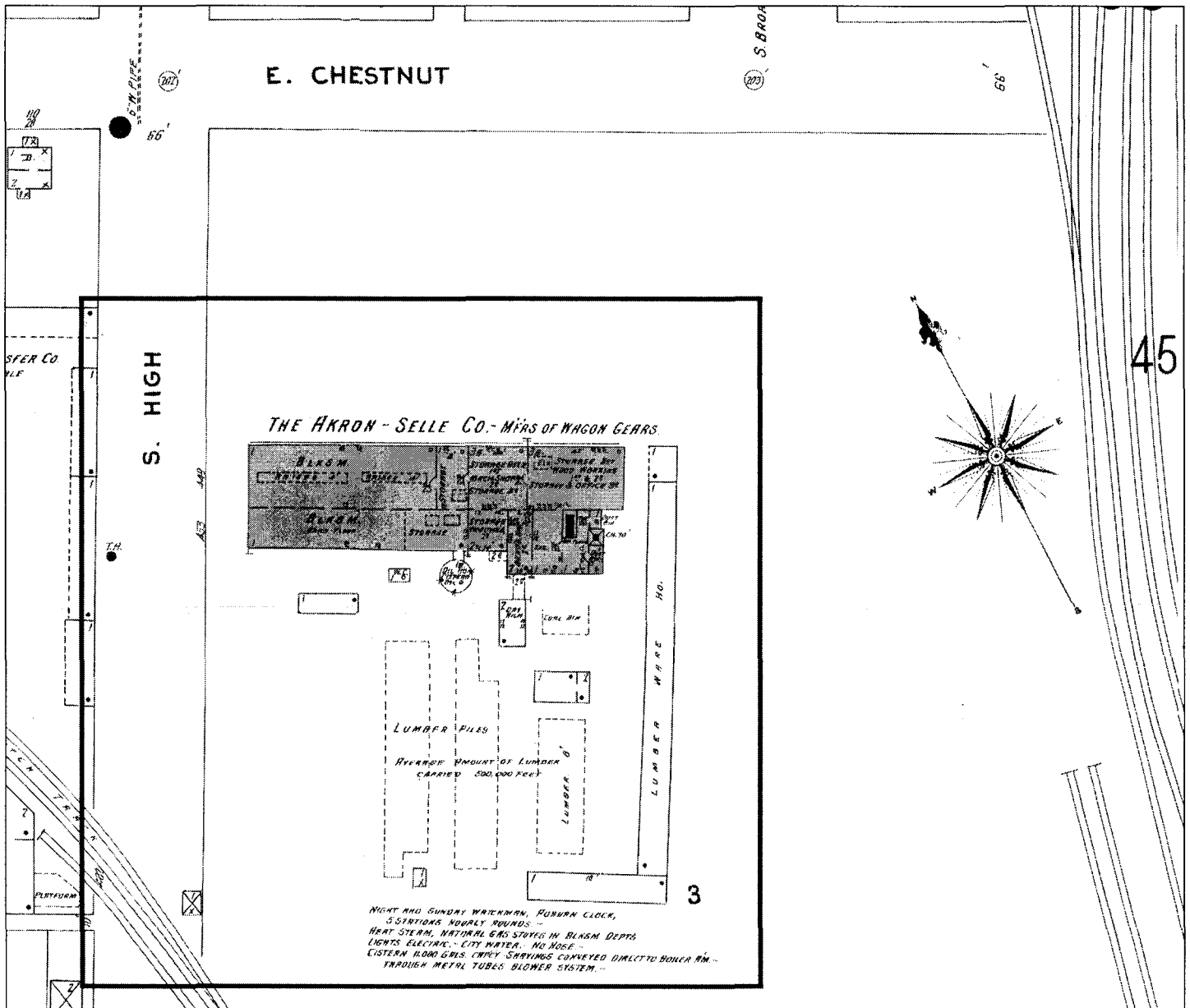

The Selle Gear Company – Surround. Akron. Sanborn Map 1904

United States Department of the Interior
National Park Service

NATIONAL REGISTER OF HISTORIC PLACES CONTINUATION SHEET

MAPS
The Selle Gear Company
Summit County, Ohio

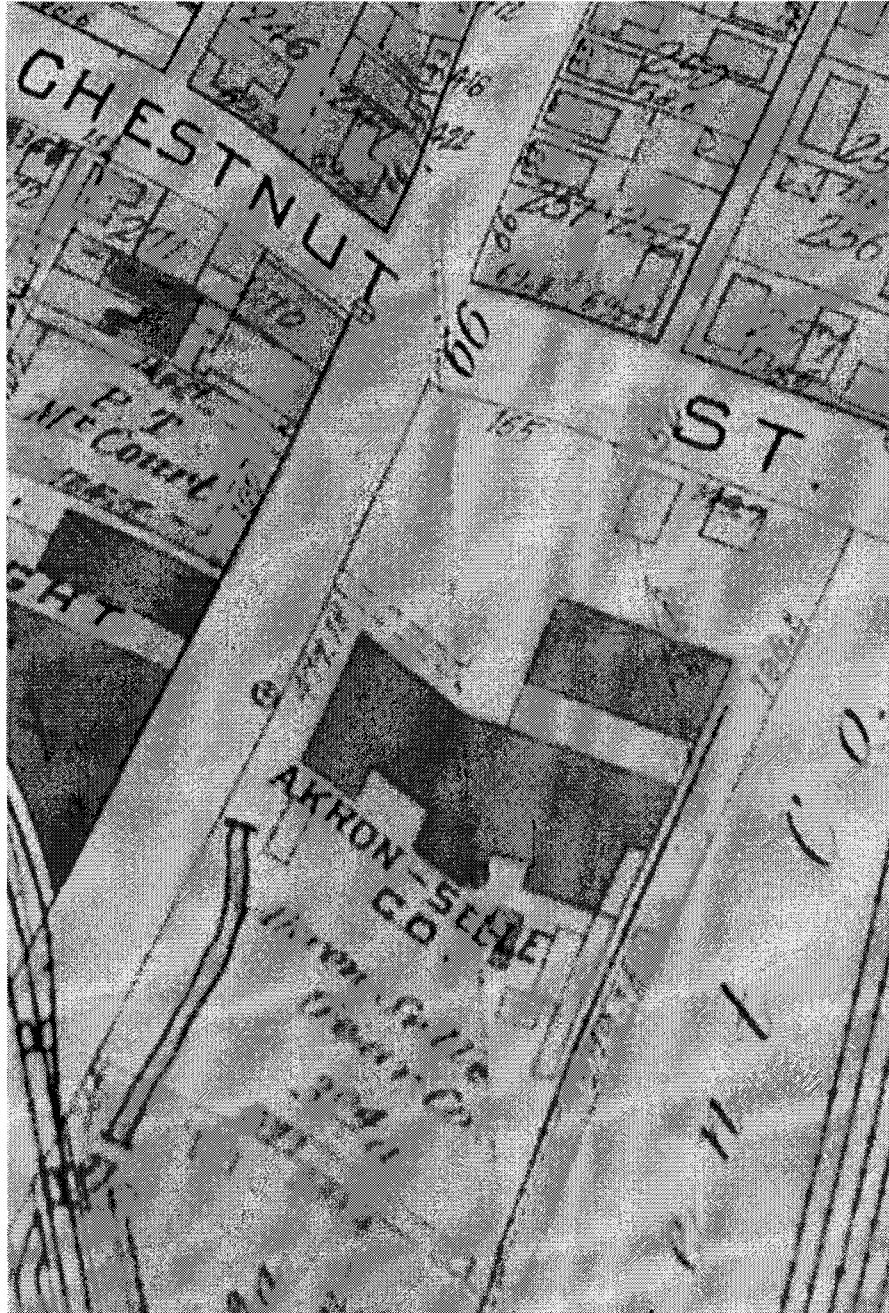

The Selle Gear Company. Akron. 1915 Atlas

United States Department of the Interior
National Park Service

NATIONAL REGISTER OF HISTORIC PLACES
CONTINUATION SHEET

MAPS
The Selle Gear Company
Summit County, Ohio

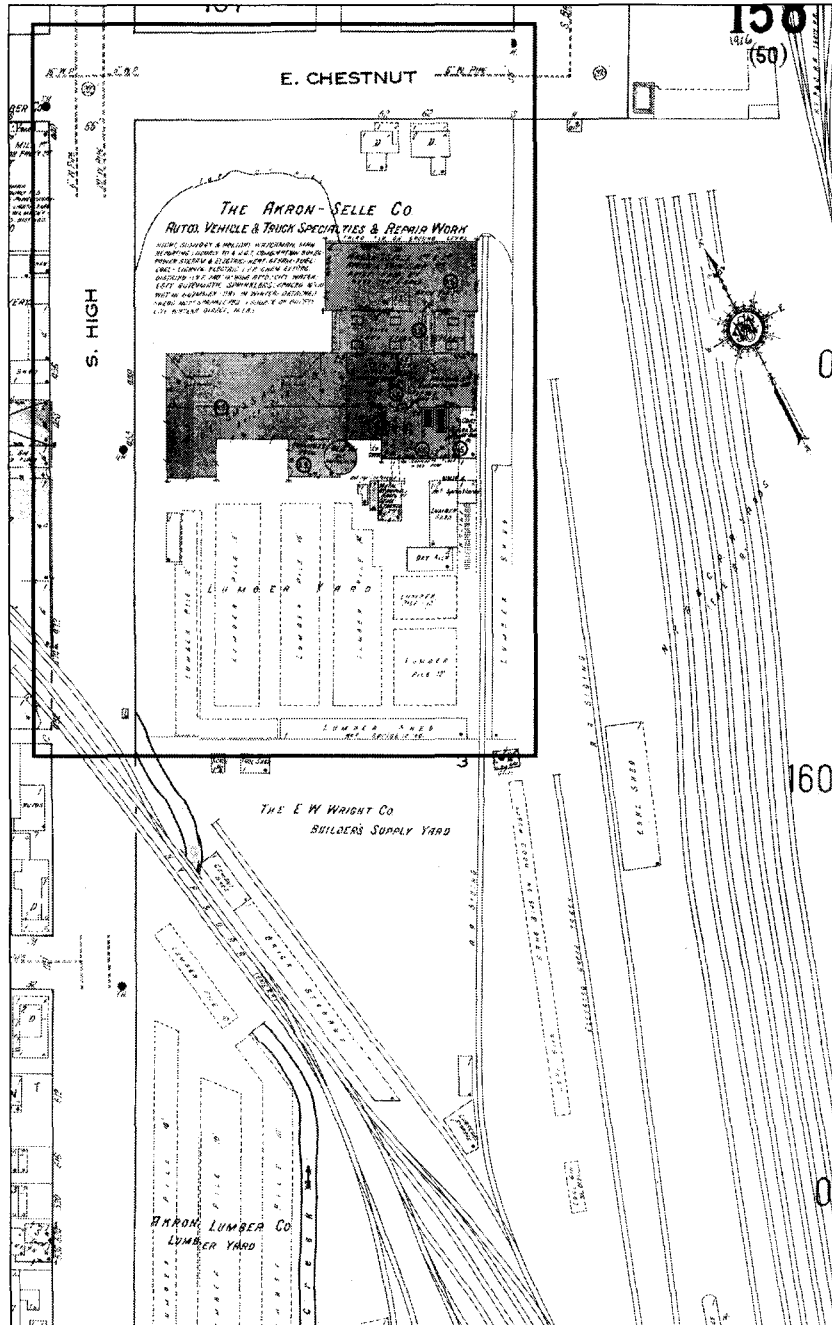

The Selle Gear Company – Surround. Akron. Sanborn Map 1916

United States Department of the Interior
National Park Service

NATIONAL REGISTER OF HISTORIC PLACES CONTINUATION SHEET

MAPS
The Selle Gear Company
Summit County, Ohio

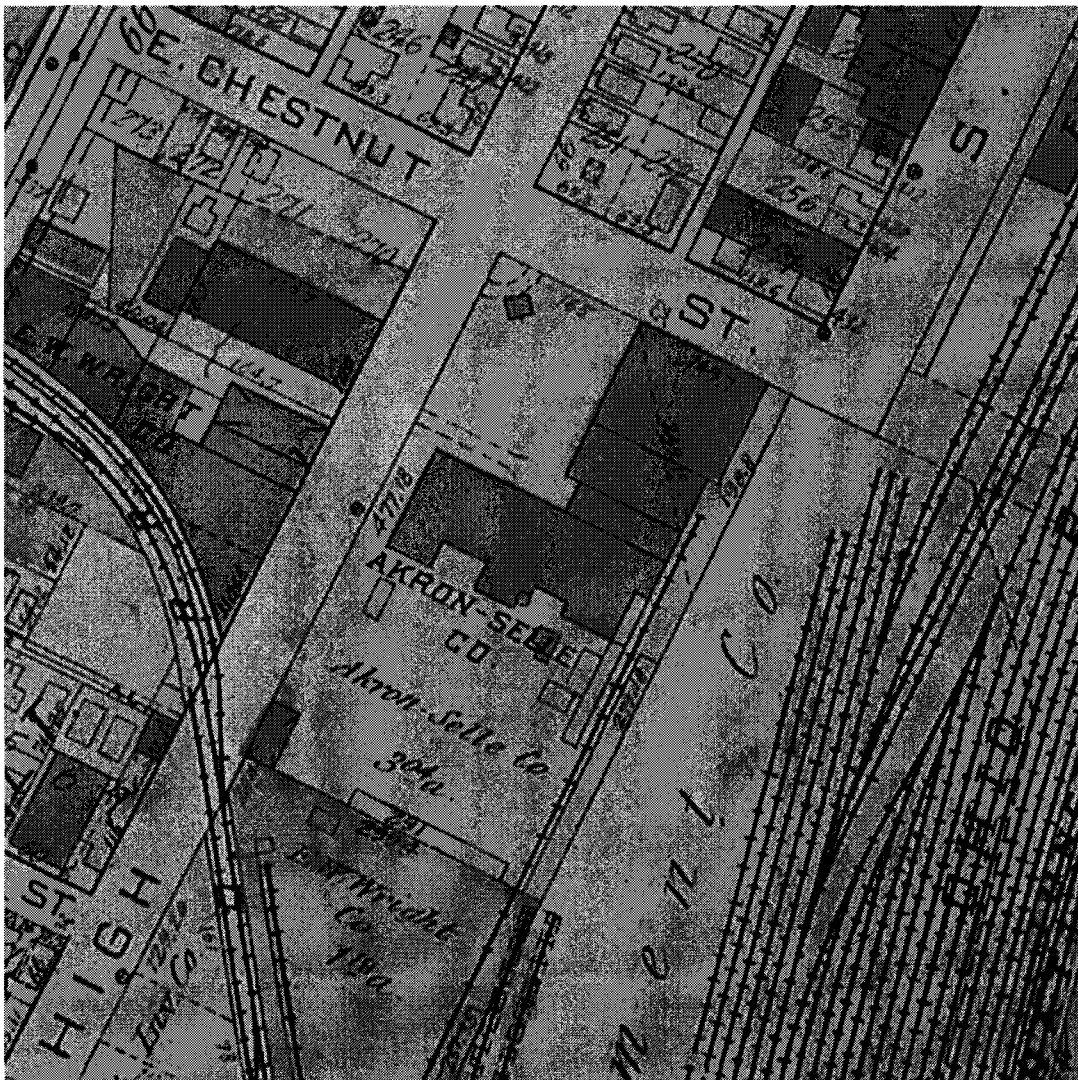

The Selle Gear Company. Akron. 1921 Atlas

United States Department of the Interior
National Park Service

NATIONAL REGISTER OF HISTORIC PLACES
CONTINUATION SHEET

MAPS
The Selle Gear Company
Summit County, Ohio

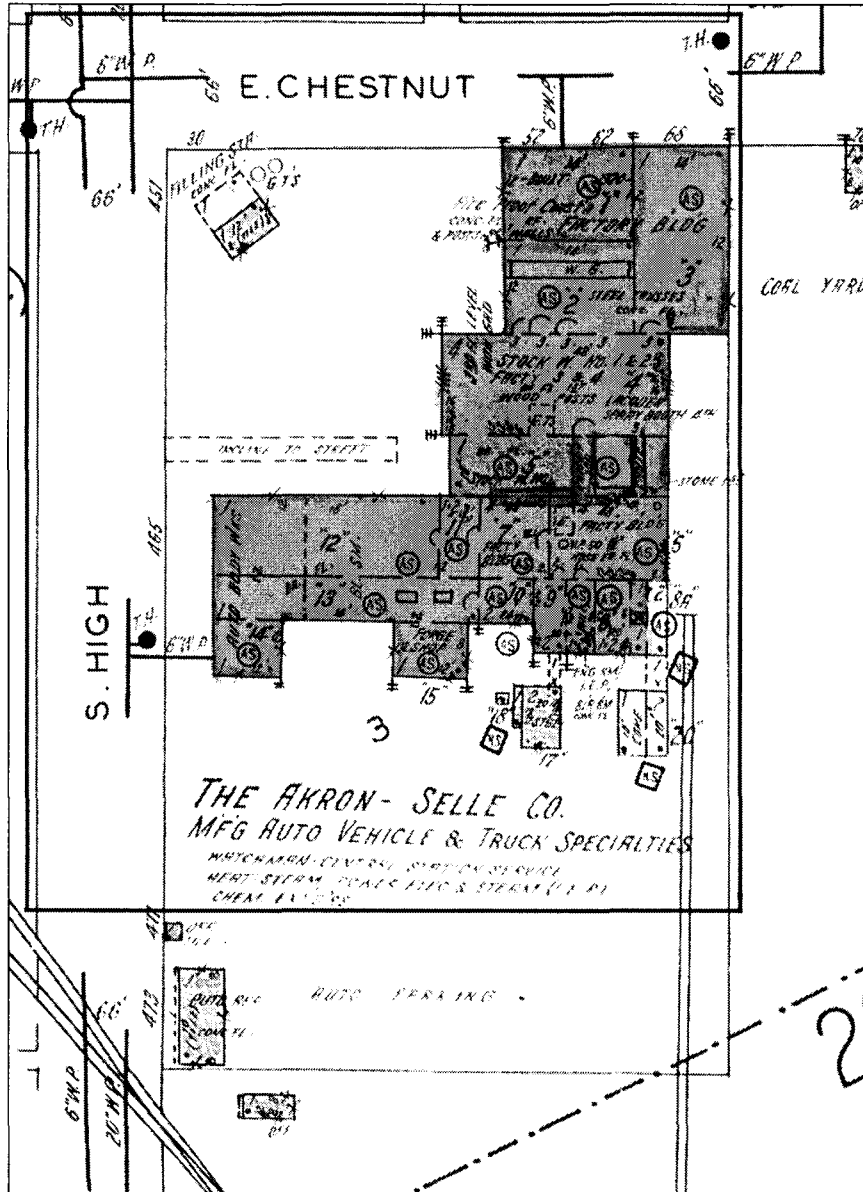

The Selle Gear Company - Surround. Akron. Sanborn Map 1940

United States Department of the Interior
National Park Service

NATIONAL REGISTER OF HISTORIC PLACES
CONTINUATION SHEET

MAPS
The Selle Gear Company
Summit County, Ohio

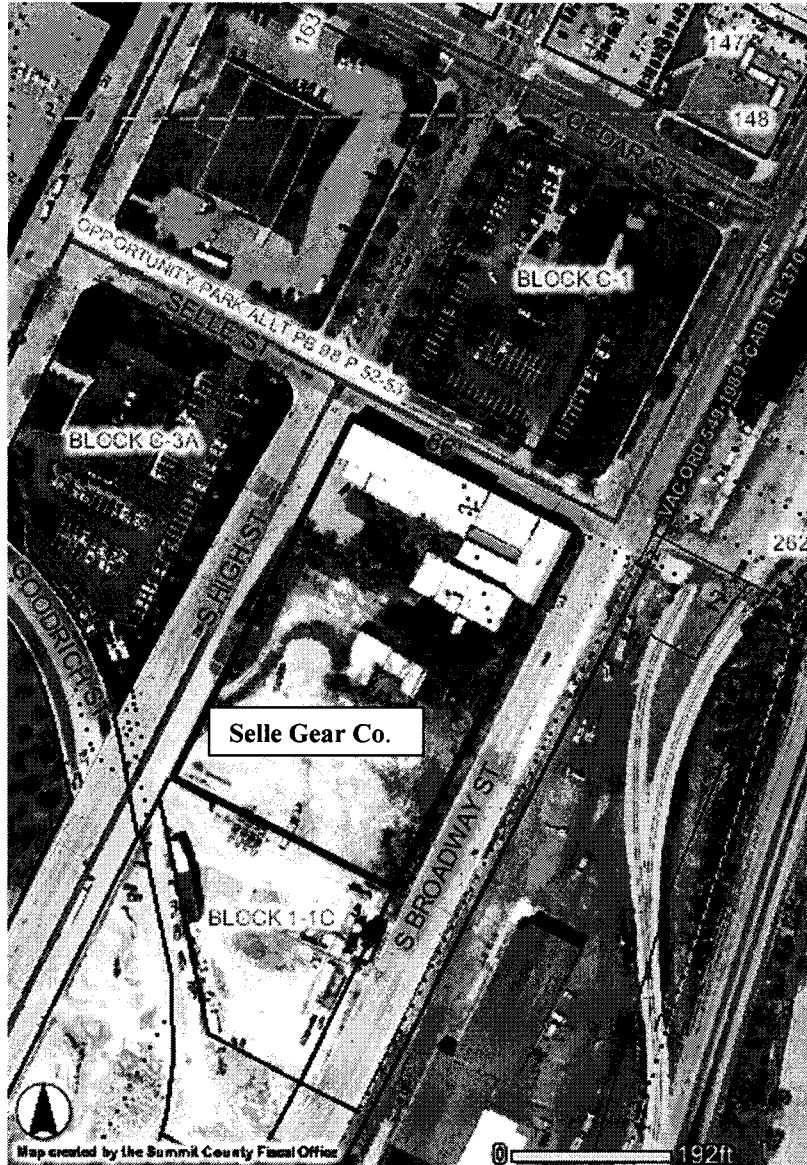

The Selle Gear Company. Akron. 2000 Aerial GIS Map. Summit County Auditor.

United States Department of the Interior
National Park Service

NATIONAL REGISTER OF HISTORIC PLACES CONTINUATION SHEET

MAPS
The Selle Gear Company
Summit County, Ohio

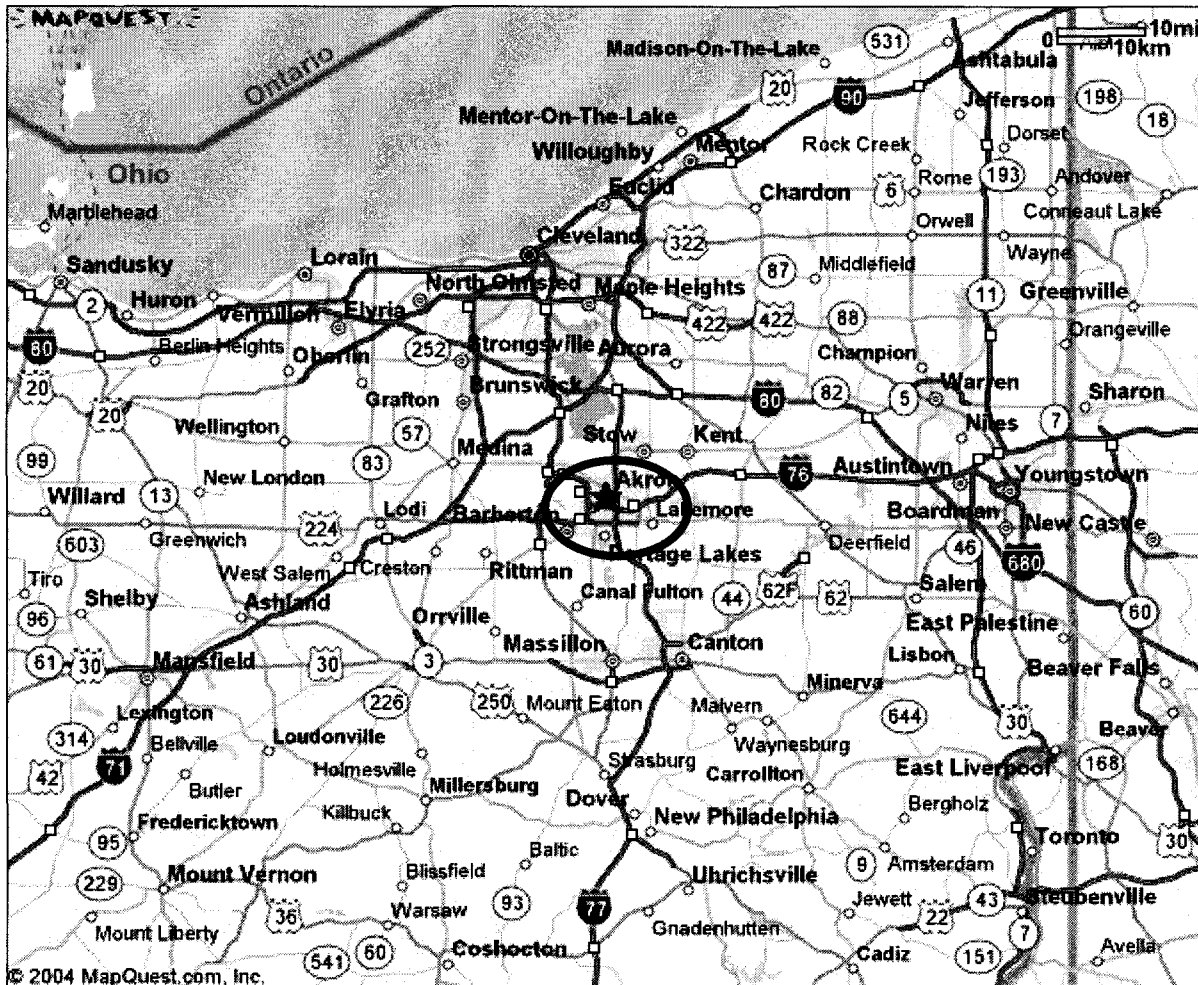

Location of Akron in the State of Ohio.

Extra Maps
7
Patent
Drawings

NPS Form 10-900
(Rev. 10-90)

024-0018

United States Department of the Interior
National Park Service

NATIONAL REGISTER OF HISTORIC PLACES CONTINUATION SHEET

PATENT LIST
Selle Gear Company
Summit County, Ohio

Page 6

(No Model.)

F. SELLE.

WAGON PLATFORM GEARING.

No. 270,254.

Patented Jan. 9, 1883.

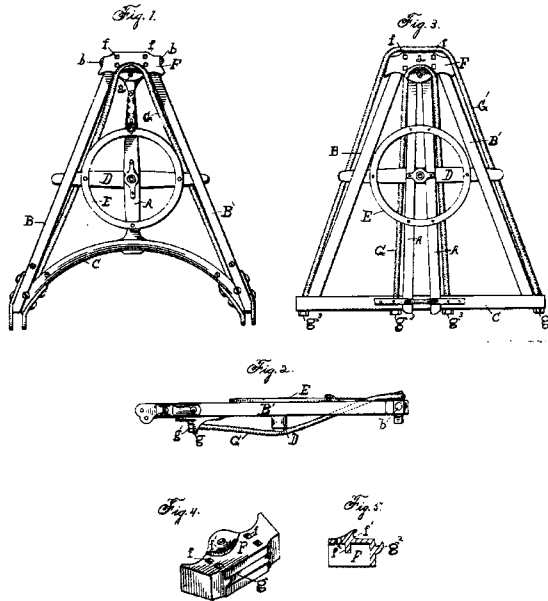

WITNESSES
Samuel C. Thomas
Richard Warren

INVENTOR
Ferdinand Selle,
by W. W. Leggett.

Selle. Wagon Platform Gearing. 1883.

United States Department of the Interior
National Park Service

NATIONAL REGISTER OF HISTORIC PLACES CONTINUATION SHEET

PATENT LIST
Selle Gear Company
Summit County, Ohio

Page 7

(No Model.)

J. G. EBERHARD.
VEHICLE HUB CAP.

No. 301,103.

Patented July 1, 1884.

Fig. 1.

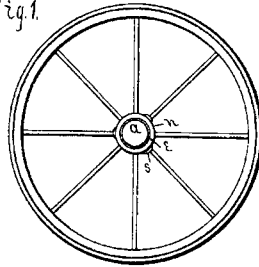

Fig. 2.



Fig. 4.



Fig. 3.



Attest
O. P. Appra
George D. Robinson

Inventor
John G. Eberhard
By Bradford Howland
Attorney

Eberhard. Vehicle Hub Cap. 1884

United States Department of the Interior
National Park Service

NATIONAL REGISTER OF HISTORIC PLACES CONTINUATION SHEET

PATENT LIST
Selle Gear Company
Summit County, Ohio

Page 8

(No Model.)

2 Sheets—Sheet 1.

F. SELLE.
WAGON REACH.

No. 346,325.

Patented July 27, 1886.

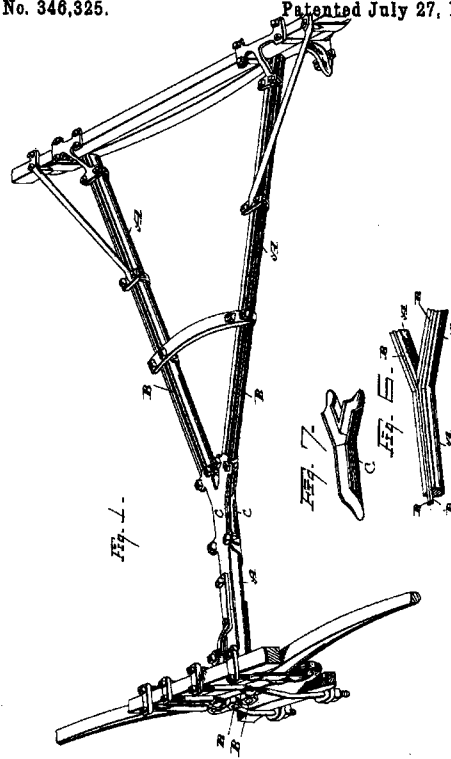

WITNESSES
M. M. Monroe
L. P. Brown

INVENTOR
Ferdinand Selle
by *Joseph E. Siggel*
Attorney

A. FITZGERALD, PHOTODUPLICATION SERVICE, S.C.

United States Department of the Interior
National Park Service

NATIONAL REGISTER OF HISTORIC PLACES CONTINUATION SHEET

PATENT LIST
Selle Gear Company
Summit County, Ohio

Page 9

(No Model.)

2 Sheets—Sheet 2.

F. SELLE.
WAGON REACH.

No. 346,325.

Patented July 27, 1886.

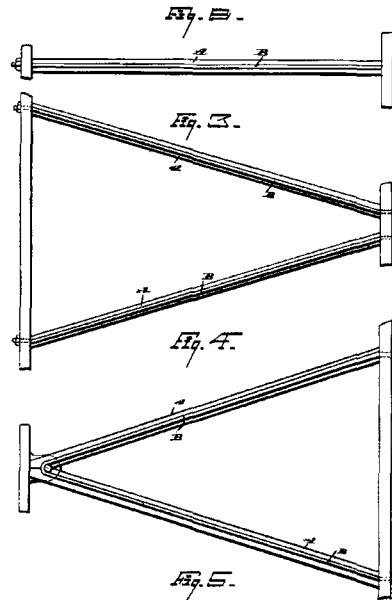

WITNESSES
Wm. M. Johnson
L. P. Over



INVENTOR
Ferdinand Selle
by *Roggett & Suggitt*
Attorneys

U. S. PATENT OFFICE, WASHINGTON, D. C.

United States Department of the Interior
National Park Service

NATIONAL REGISTER OF HISTORIC PLACES CONTINUATION SHEET

PATENT LIST
Selle Gear Company
Summit County, Ohio

(No Model.)

2 Sheets—Sheet 1.

T. H. HOLMAN.
VEHICLE PLATFORM GEAR.

No. 342,695.

Patented May 25, 1886.

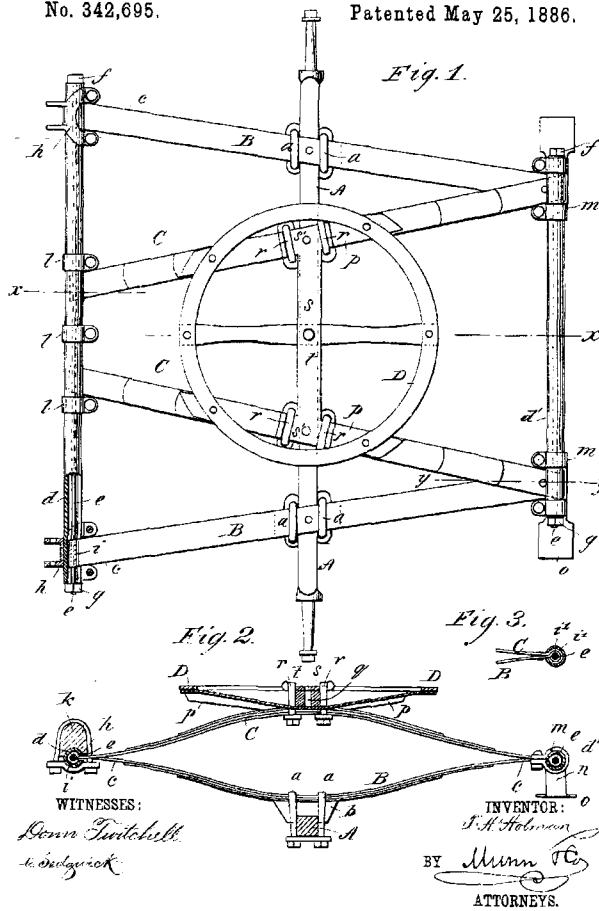

WITNESSES:
Denn Twitchell.
W. Schuyler

INVENTOR:
T. H. Holman
BY Munn & Co.
ATTORNEYS.

United States Department of the Interior
National Park Service

NATIONAL REGISTER OF HISTORIC PLACES CONTINUATION SHEET

PATENT LIST
Selle Gear Company
Summit County, Ohio

Page 11

(No Model.)

2 Sheets—Sheet 2.

T. H. HOLMAN.
VEHICLE PLATFORM GEAR.

No. 342,695.

Patented May 25, 1886.

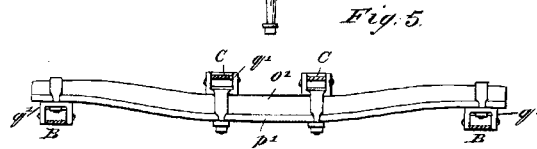
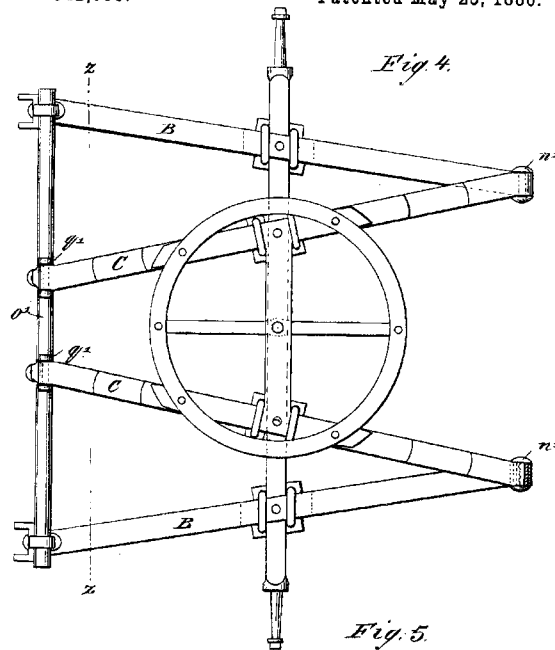

WITNESSES:
Wm. Mitchell
& Berwick

INVENTOR:
T. H. Holman
 BY *Munn & Co*
 ATTORNEYS.

* U.S. PATENT OFFICE: 1886

United States Department of the Interior
National Park Service

NATIONAL REGISTER OF HISTORIC PLACES CONTINUATION SHEET

PATENT LIST
Selle Gear Company
Summit County, Ohio

Page 12

(No Model.)

F. SELLE.
END GATE.

No. 388,002.

Patented Aug. 14, 1888.

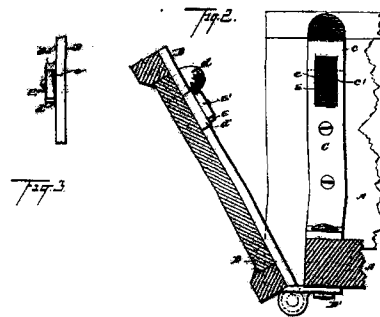
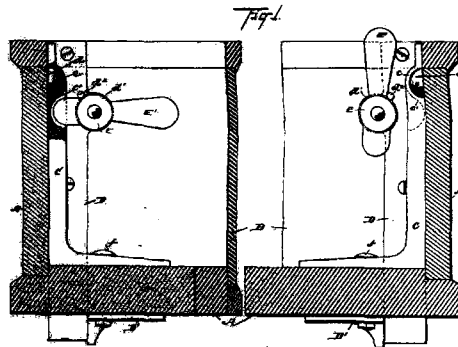

WITNESSES:
Geo. W. King

Ferdinand Selle INVENTOR.
Lyell H. Riggett ATTORNEY.

© 1888 Patent Office, Washington, D.C.

Selle. End Gate. 1888

United States Department of the Interior
National Park Service

NATIONAL REGISTER OF HISTORIC PLACES CONTINUATION SHEET

PATENT LIST
Selle Gear Company
Summit County, Ohio

Page 13

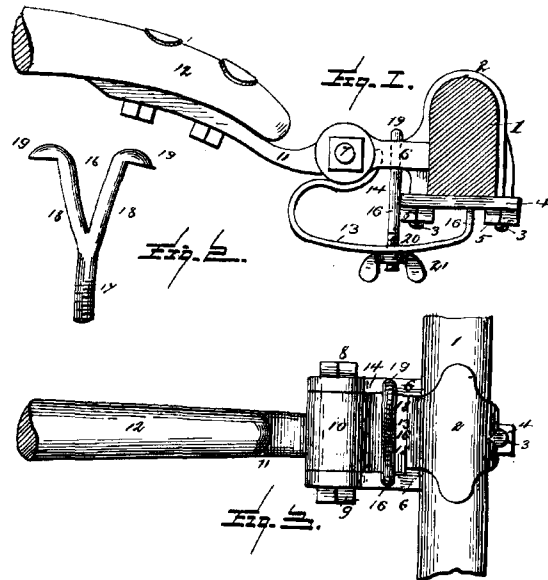

*certified to be the drawings referred to in
the specification herewith annexed.
Washington, D.C. Sept. 24, 1889.*

*Witnesses
L. C. Hills
H. Lutholants*

*Inventors:
C. & C. Lee
By C. B. Stocking
Atty.*

United States Department of the Interior
National Park Service

NATIONAL REGISTER OF HISTORIC PLACES CONTINUATION SHEET

PATENT LIST
Selle Gear Company
Summit County, Ohio

Page 14

(No Model.)

T. H. HOLMAN.
BALL BEARING FOR AXLES.

No. 563,858.

Patented July 14, 1896.

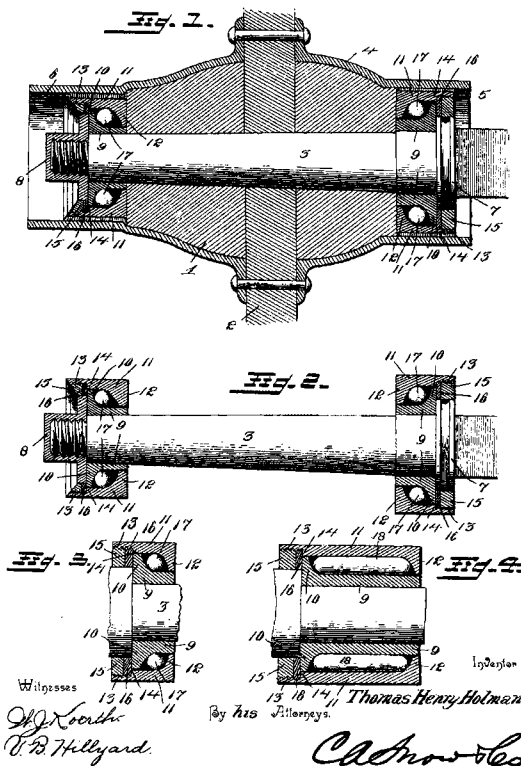

Holman. Ball Bearing for Axles. 1896

United States Department of the Interior
National Park Service

NATIONAL REGISTER OF HISTORIC PLACES CONTINUATION SHEET

PATENT LIST
Selle Gear Company
Summit County, Ohio

Page 15

(No Model.)
W. C. PARSONS
FIFTH WHEEL.
No. 592,712. Patented Oct. 26, 1897.

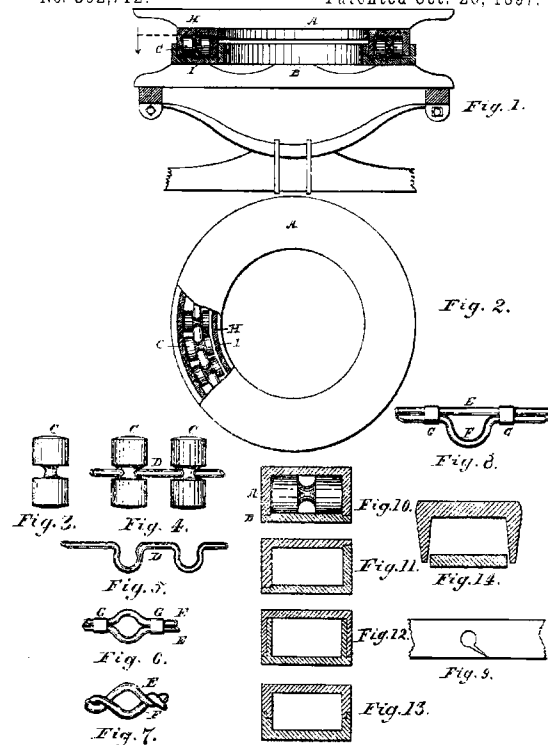

Witnesses:
H. J. Jones
John W. Thomas

Inventor:
William C. Parsons:
By Humphreys & Humphreys
Attys

United States Department of the Interior
National Park Service

NATIONAL REGISTER OF HISTORIC PLACES CONTINUATION SHEET

PATENT LIST
Selle Gear Company
Summit County, Ohio

Page 16

No. 712,070.

Patented Oct. 28, 1902.

C. JOHNSON & D. M. CAMERON.
INDICATOR FOR TANKS.
Application filed Sept. 27, 1901.

(No Model.)

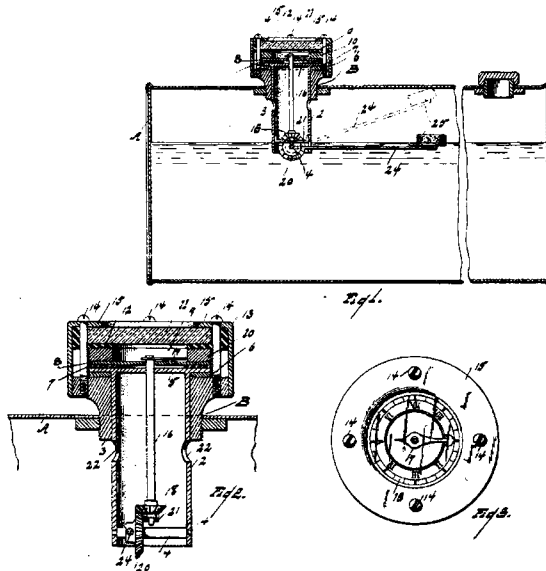

WITNESSES

J. J. Mearns
Edna L. Rayton

INVENTORS

Clark Johnson
Donald M. Cameron
By *Park & Burton* Attorneys.

Johnson-Cameron. Indicator for Tanks. 1902

United States Department of the Interior
National Park Service

NATIONAL REGISTER OF HISTORIC PLACES CONTINUATION SHEET

PATENT LIST
Selle Gear Company
Summit County, Ohio

Page 17

No. 776,591.

PATENTED DEC. 6, 1904.

M. O. HOWER.
CLINKER CATCHER.
APPLICATION FILED FEB. 24, 1904.

NO MODEL.

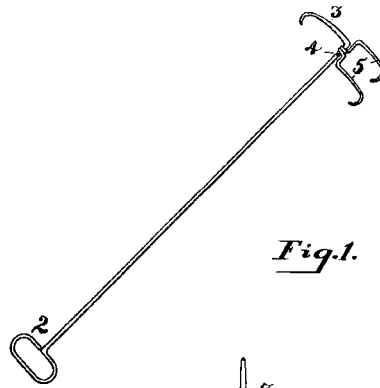

Fig. 1.

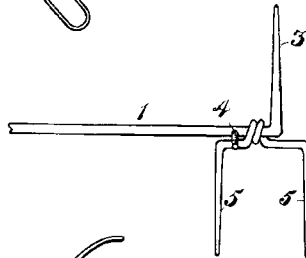

Fig. 2.

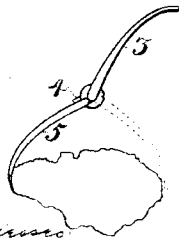

Fig. 3.

*Witness
Maude G. ...
G. W. ...*

*Inventor:
Milton O. Hower,
By C. Callaway, Esq.
Att'y.*

United States Department of the Interior
National Park Service

NATIONAL REGISTER OF HISTORIC PLACES CONTINUATION SHEET

PATENT LIST
Selle Gear Company
Summit County, Ohio

Page 18

No. 867,994.

PATENTED OCT. 15, 1907.

L. MURPHY.

APPARATUS FOR INDICATING THE DEPTH OF LIQUID IN A VESSEL.

APPLICATION FILED JAN. 30, 1907.

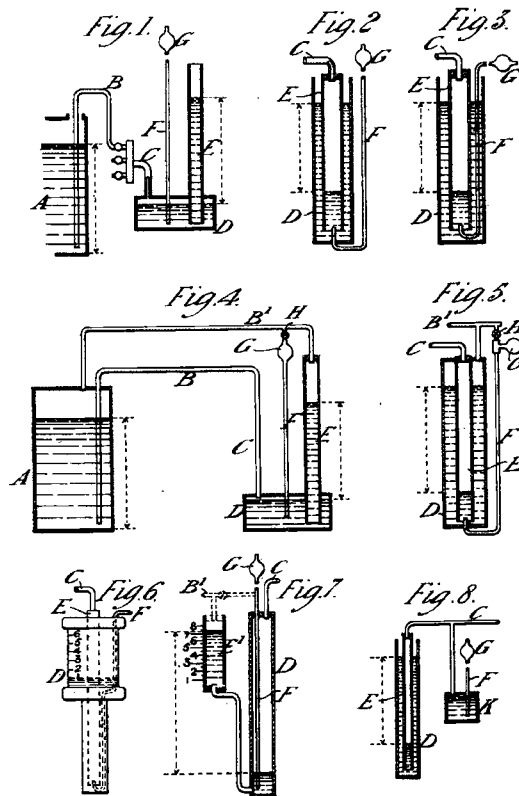

Witnesses.
L. M. Conine
M. V. Kehl

Inventor
L. Murphy
by *Robert A. Dyer*
his atty

United States Department of the Interior
National Park Service

NATIONAL REGISTER OF HISTORIC PLACES CONTINUATION SHEET

PATENT LIST
Selle Gear Company
Summit County, Ohio

No. 854,481.

PATENTED MAY 21, 1907.

P. M. FREER.
AUTOMATIC GAGE.
APPLICATION FILED SEPT. 12, 1906.

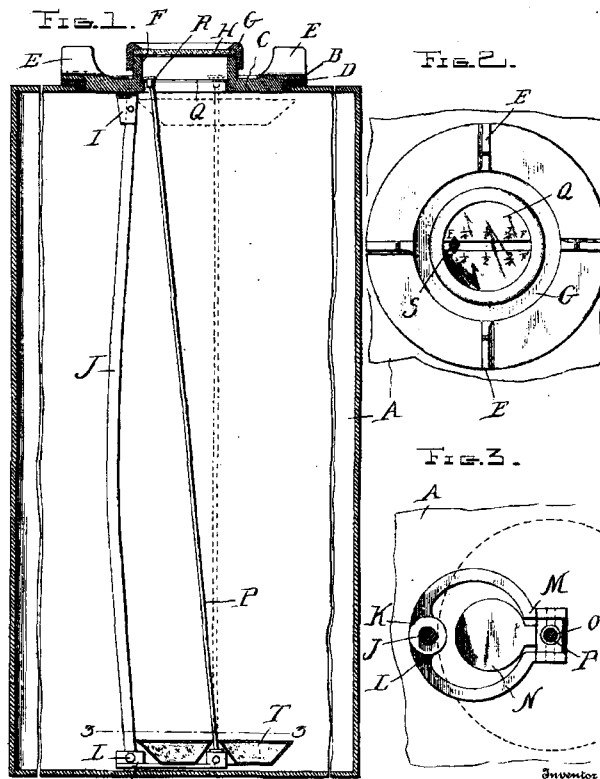

Witnesses
Jan. A. Koehl.
C. B. Hartman

Phelp M. Freer
James W. Brown, Attorney

United States Department of the Interior
National Park Service

NATIONAL REGISTER OF HISTORIC PLACES CONTINUATION SHEET

PATENT LIST
Selle Gear Company
Summit County, Ohio

Page 20

No. 885,059.

PATENTED APR. 21, 1908.

J. B. LAURSEN.
INDICATOR FOR TANKS.
APPLICATION FILED APR. 11, 1907.

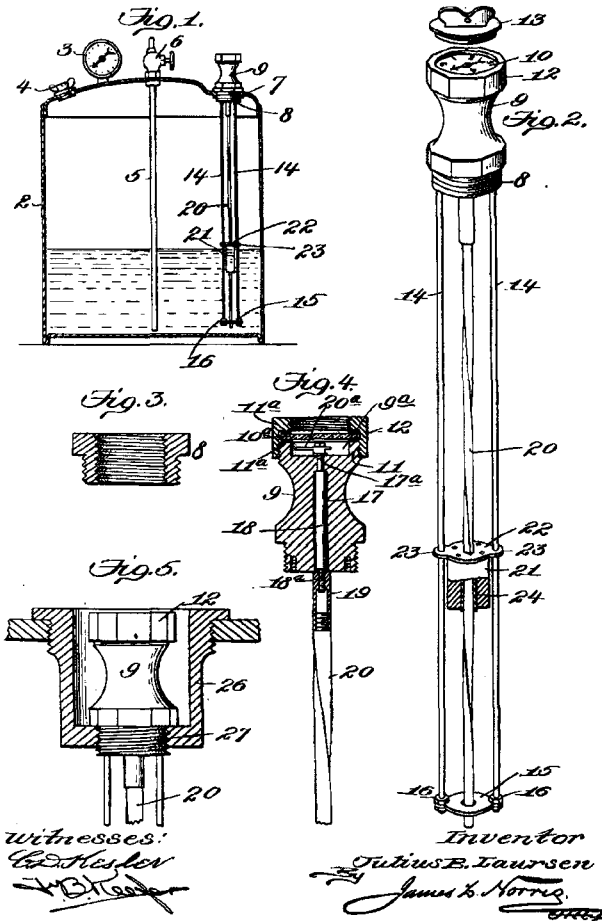

United States Department of the Interior
National Park Service

NATIONAL REGISTER OF HISTORIC PLACES CONTINUATION SHEET

PATENT LIST
Selle Gear Company
Summit County, Ohio

Page 21

No. 885,675.

PATENTED APR. 21, 1908.

M. MARTIN.
FLUID LEVEL INDICATOR.
APPLICATION FILED APR. 5, 1907.

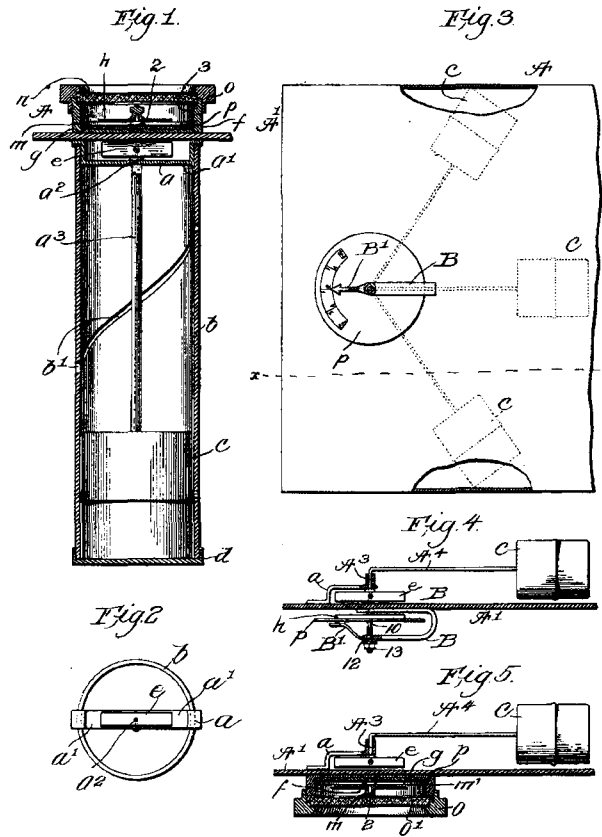

Witnesses.
H. C. Lumsford
Joseph M. Wood.

Inventor.
Morris Martin,
By *[Signature]* Attorney.

THE MERRILL PATENT CO., WASHINGTON, D. C.

United States Department of the Interior
National Park Service

NATIONAL REGISTER OF HISTORIC PLACES CONTINUATION SHEET

PATENT LIST
Selle Gear Company
Summit County, Ohio

Page 22

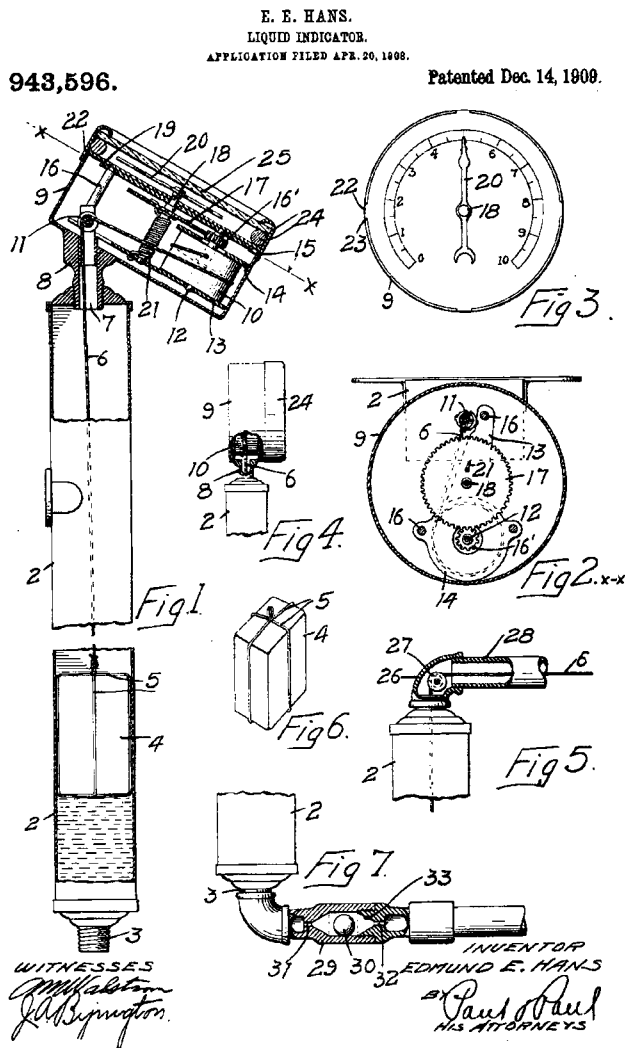

Hans. Liquid Indicator. 1909

United States Department of the Interior
National Park Service

NATIONAL REGISTER OF HISTORIC PLACES CONTINUATION SHEET

PATENT LIST
Selle Gear Company
Summit County, Ohio

Tank Gauge

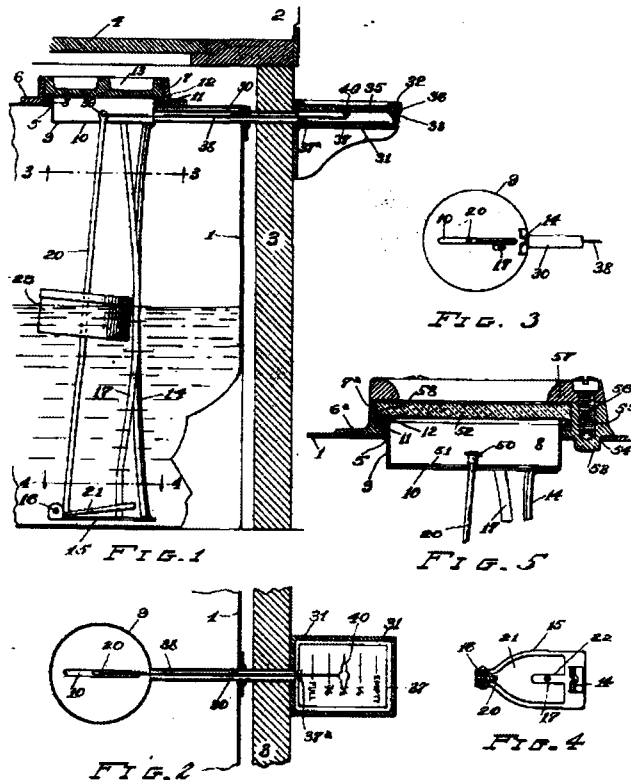

Witness:
B. Moore

Certified to be the drawings referred to in the specification hereto annexed
Cleveland, Ohio, USA, Oct 25, 1911

INVENTOR
William F. Warden
BY
Hull & Smith
ATTORNEYS.

Warden. Tank Gauge. 1911

United States Department of the Interior
National Park Service

NATIONAL REGISTER OF HISTORIC PLACES CONTINUATION SHEET

PATENT LIST
Selle Gear Company
Summit County, Ohio

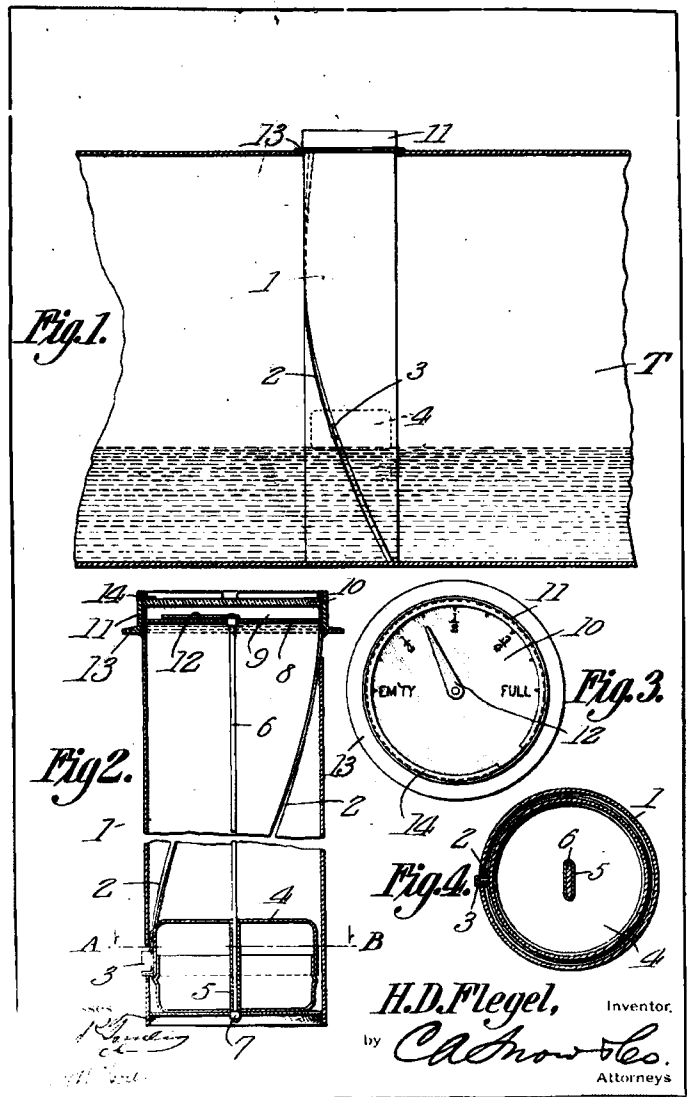

Flegel Gage. 1912

United States Department of the Interior
National Park Service

NATIONAL REGISTER OF HISTORIC PLACES CONTINUATION SHEET

PATENT LIST
Selle Gear Company
Summit County, Ohio

Page 25

F. L. PFAHL.
INDICATOR FOR LIQUID CONTAINERS.
APPLICATION FILED FEB. 6, 1911
Patented Jan. 2, 1912.
2 SHEETS-SHEET 2

1,013,309.

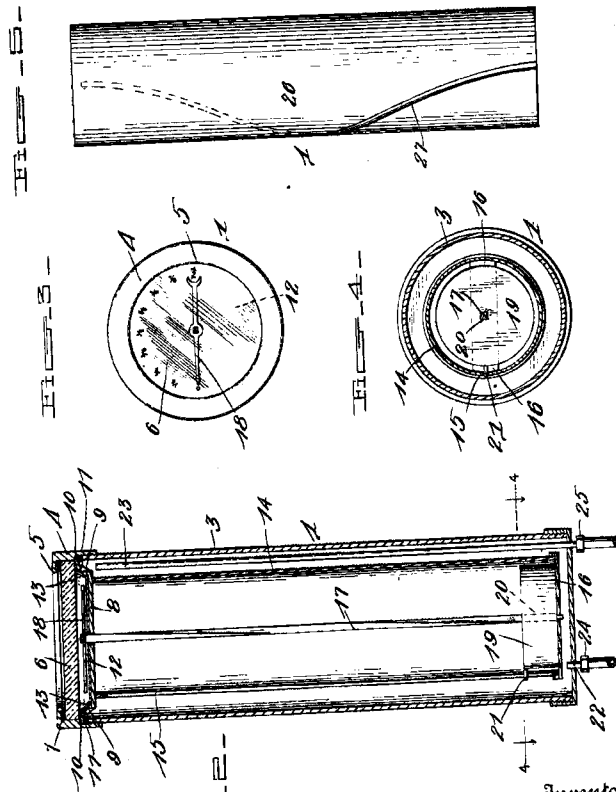

Witnesses
L. B. James
C. B. Hopkins

Inventor
F. L. Pfahl.
by *A. P. Wilson*
Attorney

United States Department of the Interior
National Park Service

NATIONAL REGISTER OF HISTORIC PLACES CONTINUATION SHEET

PATENT LIST
Selle Gear Company
Summit County, Ohio

Page 26

F. W. WALRAVEN & C. E. CALKINS.
WATER GAGE.
APPLICATION FILED AUG. 7, 1912.

1,075,881.

Patented Oct. 14, 1913.

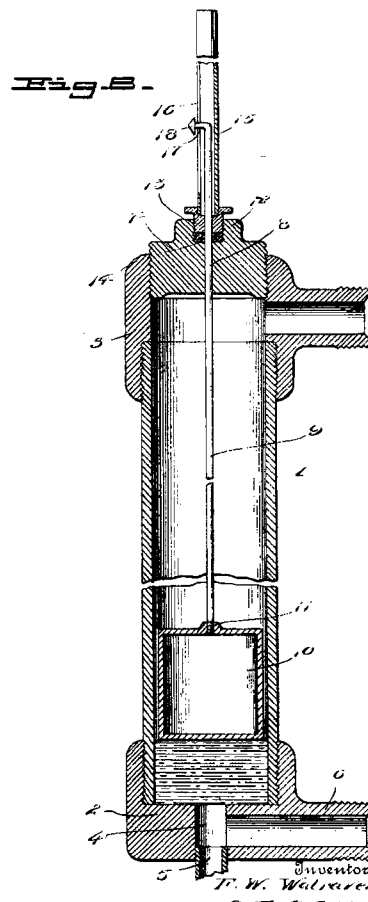
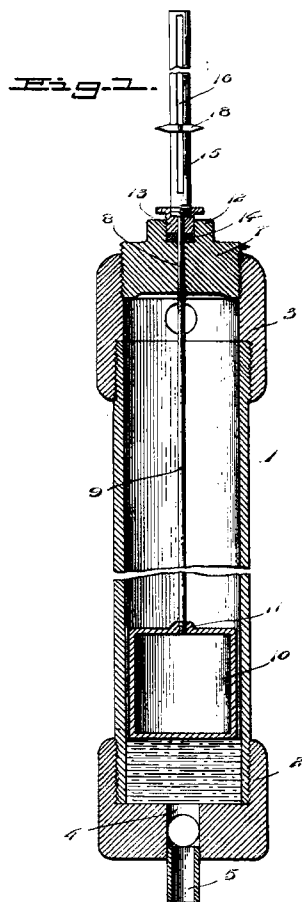

Witnesses
C. E. Kumpfer
R. M. Smith

Inventors
F. W. Walraven
C. E. Calkins

Victor J. Evans
Attorney

United States Department of the Interior
National Park Service

NATIONAL REGISTER OF HISTORIC PLACES CONTINUATION SHEET

PATENT LIST
Selle Gear Company
Summit County, Ohio

Page 27

P. E. TANNER.
GAGE FOR LIQUID CONTAINING TANKS.
APPLICATION FILED JUNE 18, 1914.

1,129,837.

Patented Feb. 23, 1915.

2 SHEETS-SHEET 1

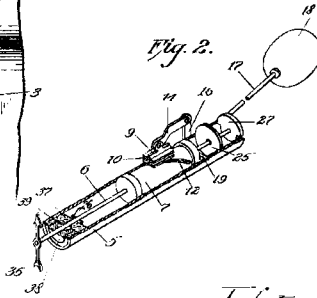
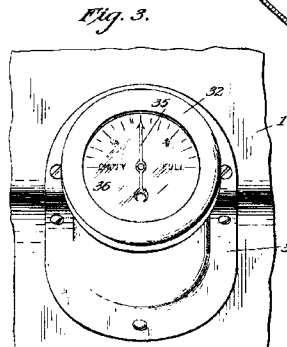
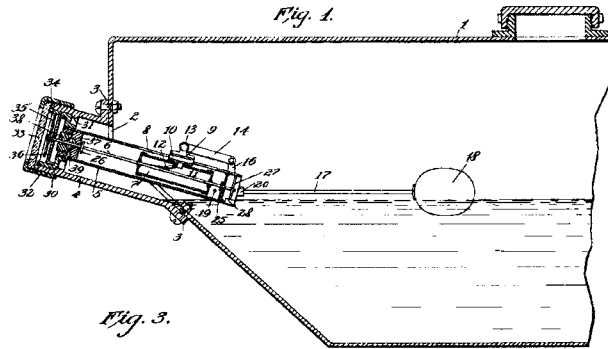

Witnesses:
R. A. Duck.
H. B. McMill

Inventor,
Perry E. Tanner
By *Hull & Smith*
Atty.

1129-837-1-1

Tanner. Gage for Liquid Containing Tanks. 1915

United States Department of the Interior
National Park Service

NATIONAL REGISTER OF HISTORIC PLACES CONTINUATION SHEET

PATENT LIST
Selle Gear Company
Summit County, Ohio

Page 28

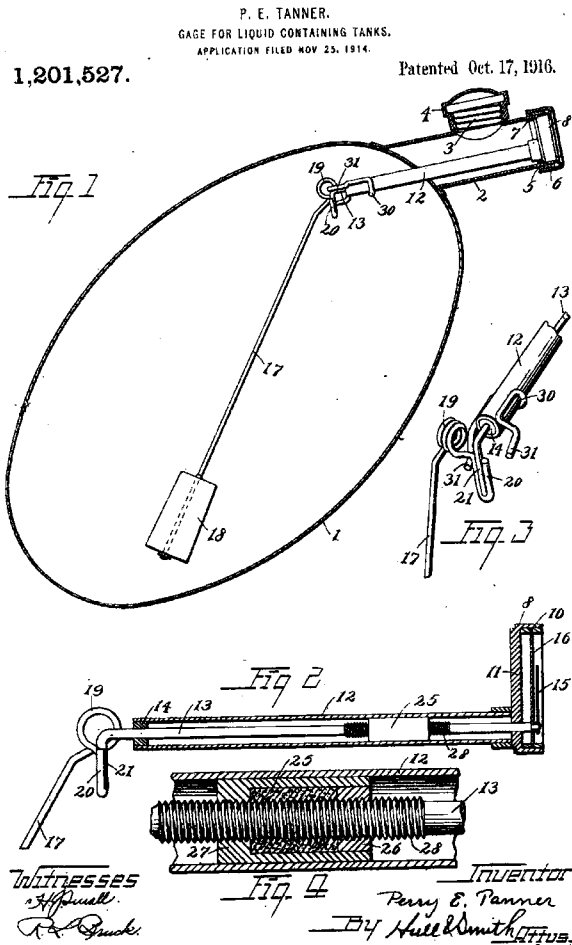

Tanner. Gage for Liquid Containing Tanks. 1916

United States Department of the Interior
National Park Service

NATIONAL REGISTER OF HISTORIC PLACES CONTINUATION SHEET

PATENT LIST
Selle Gear Company
Summit County, Ohio

Page 29

H. D. FLEGEL.
LIQUID GAGE.
APPLICATION FILED AUG. 28, 1914.

Reissued June 5, 1917.

14,314.

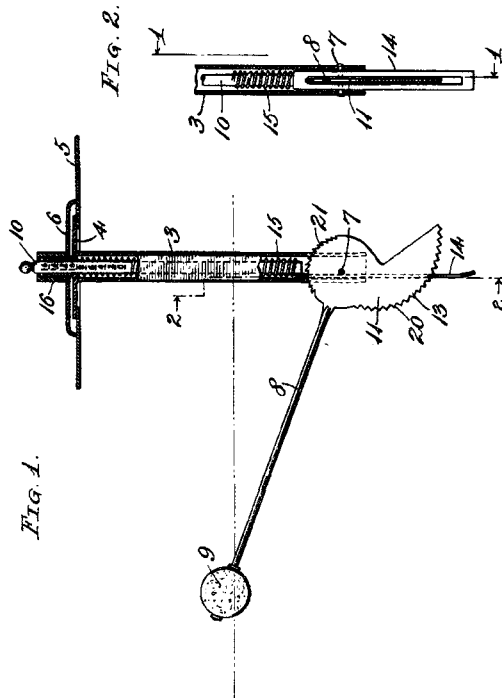

Witnesses:
Bourmont B. Jaast
Hugh B. Merrill

Inventor.
Harrison D. Flegel
By Hull & Smith Att'y.

THE ROBERTS PATENT CO. WASHINGTON, D. C.

Flegel Liquid Gage. 1917

United States Department of the Interior
National Park Service

NATIONAL REGISTER OF HISTORIC PLACES CONTINUATION SHEET

PATENT LIST
Selle Gear Company
Summit County, Ohio

Page 30

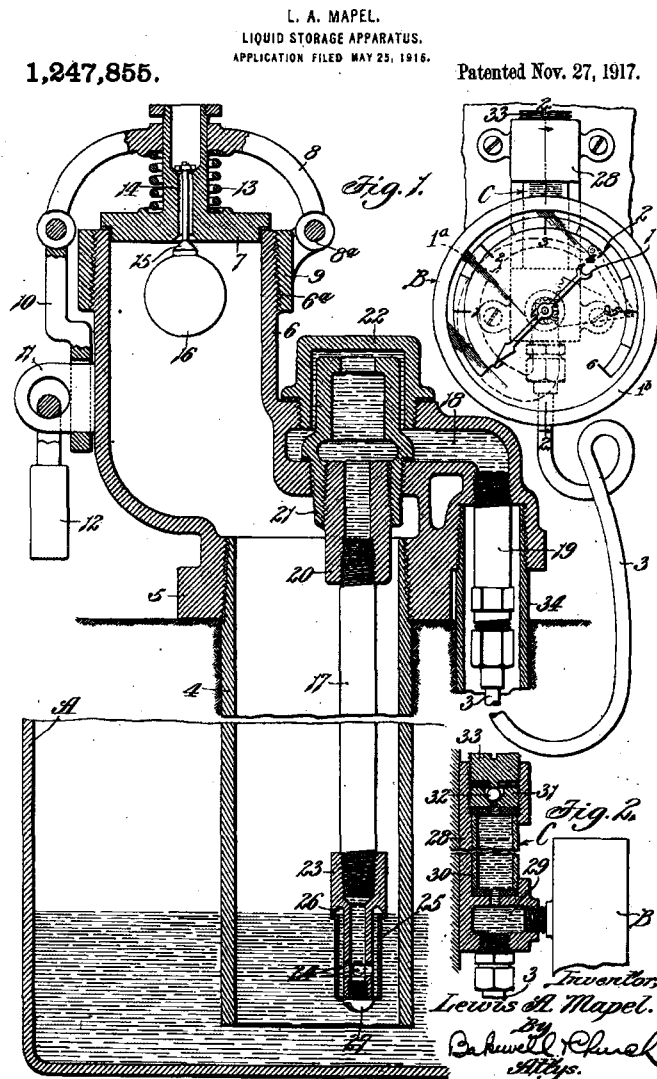

Mapel. Liquid Storage Apparatus. 1917

United States Department of the Interior
National Park Service

NATIONAL REGISTER OF HISTORIC PLACES CONTINUATION SHEET

PATENT LIST
Selle Gear Company
Summit County, Ohio

Page 31

E. E. HUFEMAN AND O. W. COWGILL.
DEPTH INDICATING DEVICE.
APPLICATION FILED DEC. 4, 1917.

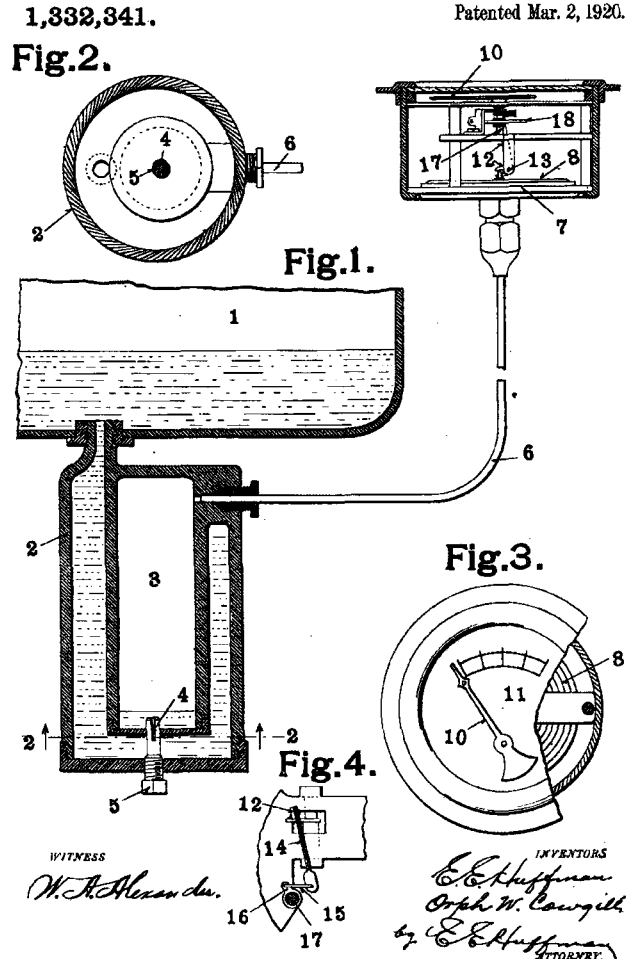

Huffman-Cowgill. Depth Indicating Device. 1920

United States Department of the Interior
National Park Service

NATIONAL REGISTER OF HISTORIC PLACES CONTINUATION SHEET

PATENT LIST
Selle Gear Company
Summit County, Ohio

Page 32

H. W. KING.
DEPTH INDICATING DEVICE.
APPLICATION FILED JAN. 29, 1919.
1,364,503. Patented Jan. 4, 1921.

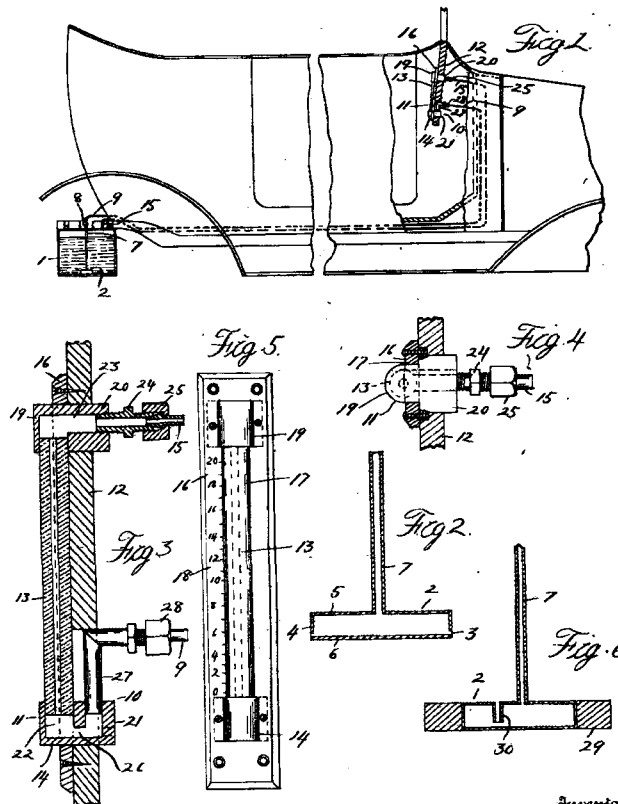

Inventor
Horace W. King
By *Whitmore H. H. Whitmore*
Attorney

United States Department of the Interior
National Park Service

NATIONAL REGISTER OF HISTORIC PLACES CONTINUATION SHEET

PATENT LIST
Selle Gear Company
Summit County, Ohio

Page 33

H. W. KING.
DEPTH INDICATING DEVICE.
APPLICATION FILED MAY 23, 1919.
1,364,504. Patented Jan. 4, 1921.

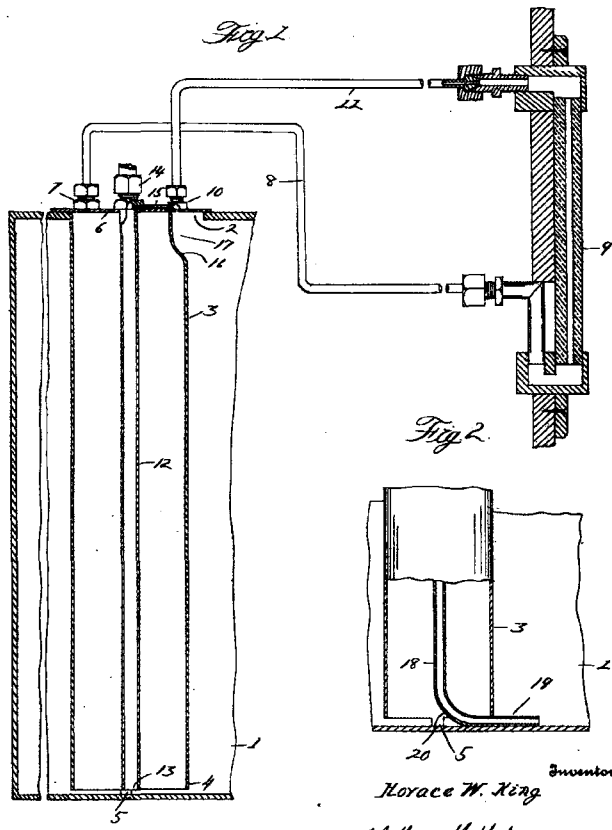

Inventor
Horace W. King
By *Whitmore Hubert Whitmore*
Attorney

King. Depth Indicating Device. May 1919/1921

United States Department of the Interior
National Park Service

NATIONAL REGISTER OF HISTORIC PLACES CONTINUATION SHEET

PATENT LIST
Selle Gear Company
Summit County, Ohio

Page 34

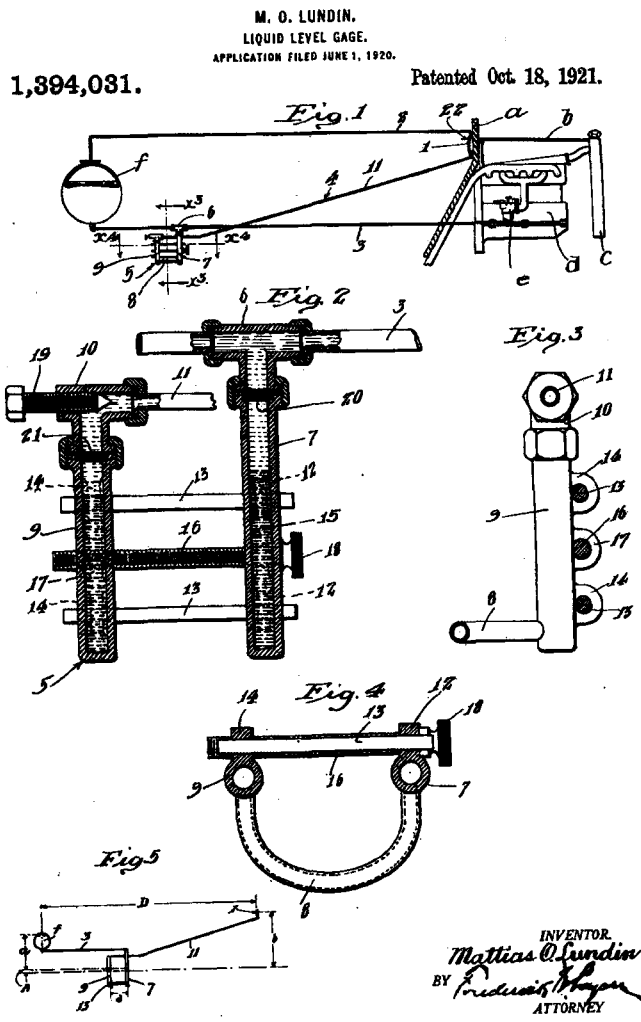

Lundin.Liquid Level Gage. 1921

United States Department of the Interior
National Park Service

NATIONAL REGISTER OF HISTORIC PLACES CONTINUATION SHEET

PATENT LIST
Selle Gear Company
Summit County, Ohio

Page 35

Nov. 8, 1927.

J. B. MOWER ET AL
LIQUID GAUGE
Filed March 5, 1923

1,648,731

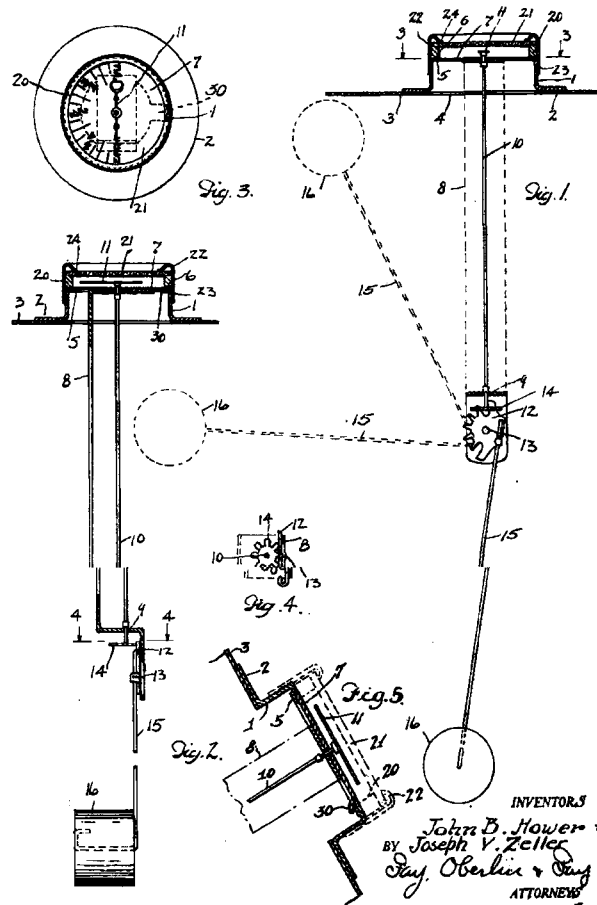

INVENTORS
John B. Mower &
BY Joseph V. Zeller
Ray Oberlin & Ray
ATTORNEYS

J.Hower-Zeller. Liquid Gage. 1927

United States Department of the Interior
National Park Service

NATIONAL REGISTER OF HISTORIC PLACES CONTINUATION SHEET

PATENT LIST
Selle Gear Company
Summit County, Ohio

Page 36

July 24, 1928.

J. B. HOWER ET AL
LIQUID GAUGE
Filed March 5, 1923

1,678,513

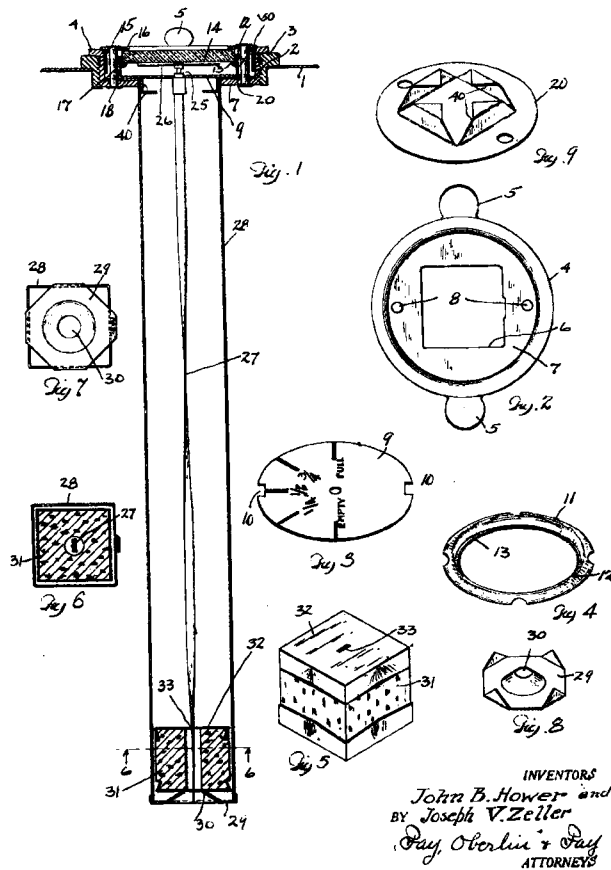

J.Hower-Zeller. Liquid Gage. 1928

United States Department of the Interior
National Park Service

NATIONAL REGISTER OF HISTORIC PLACES CONTINUATION SHEET

MAPS
The Selle Gear Company
Summit County, Ohio

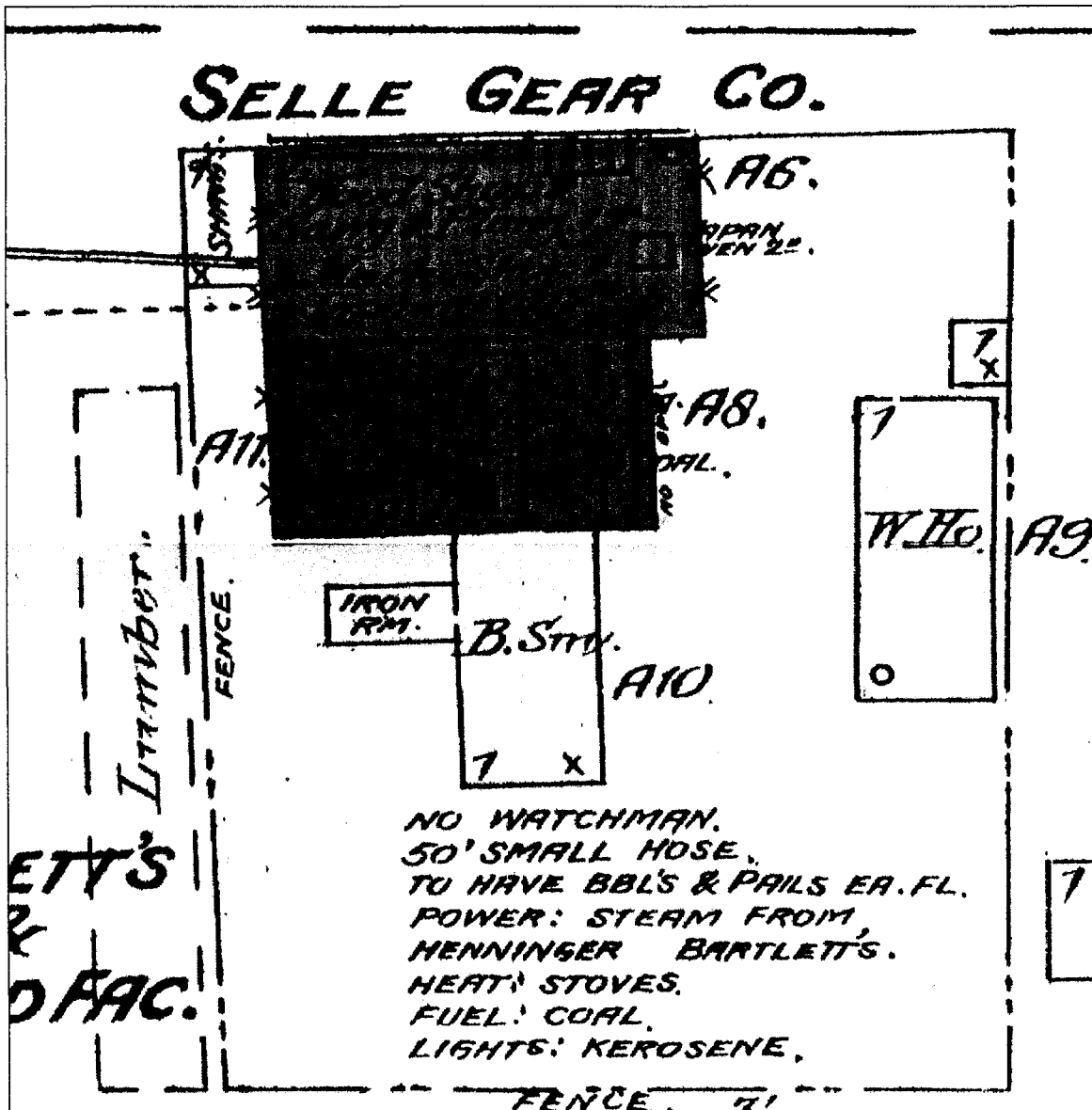

The Selle Gear Company – original location - detail. Akron. Sanborn Map 1886

United States Department of the Interior
National Park Service

NATIONAL REGISTER OF HISTORIC PLACES CONTINUATION SHEET

MAPS
The Selle Gear Company
Summit County, Ohio

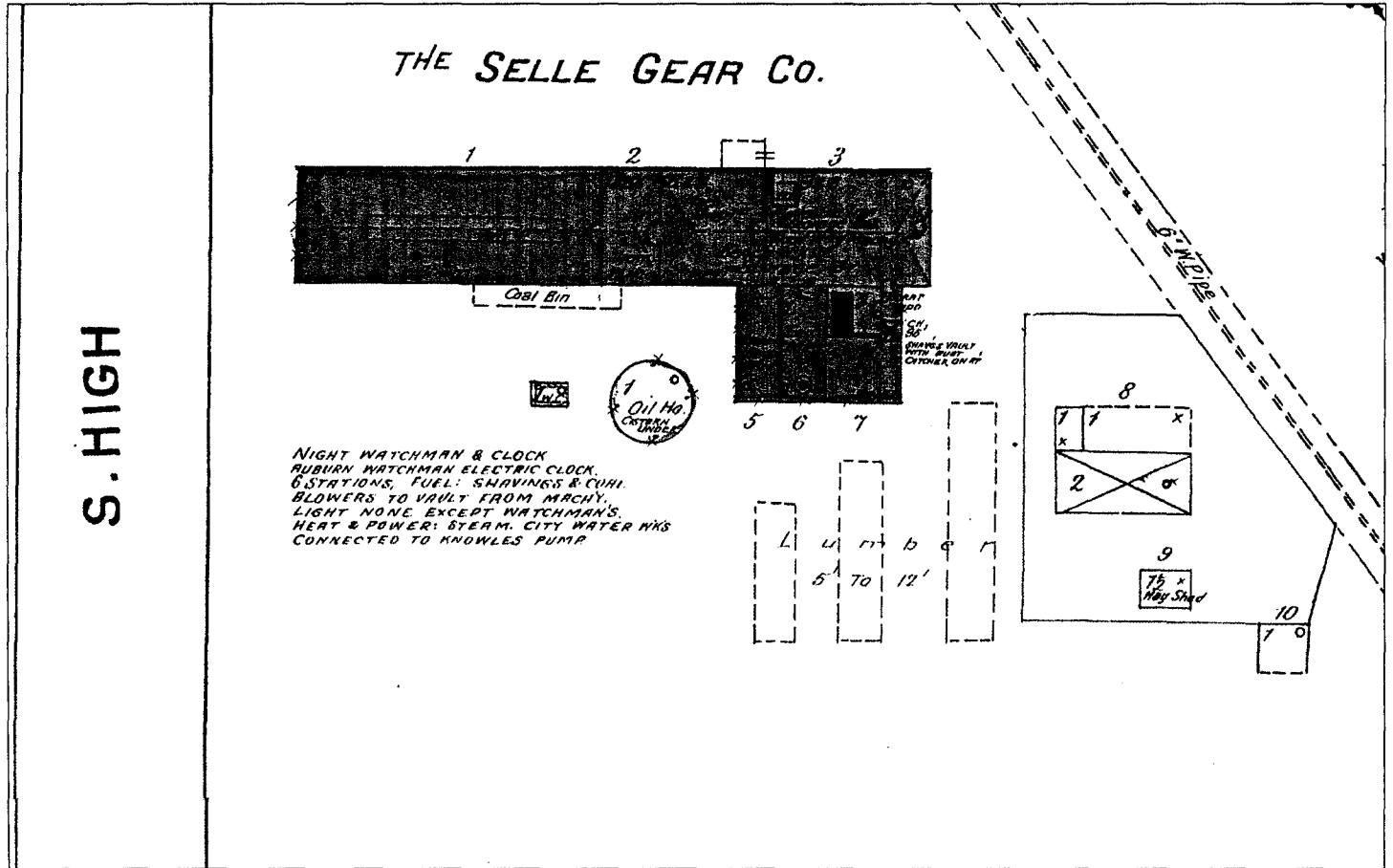

The Selle Gear Company - Site. Akron. Sanborn Map 1892

United States Department of the Interior
National Park Service

NATIONAL REGISTER OF HISTORIC PLACES CONTINUATION SHEET

MAPS
The Selle Gear Company
Summit County, Ohio

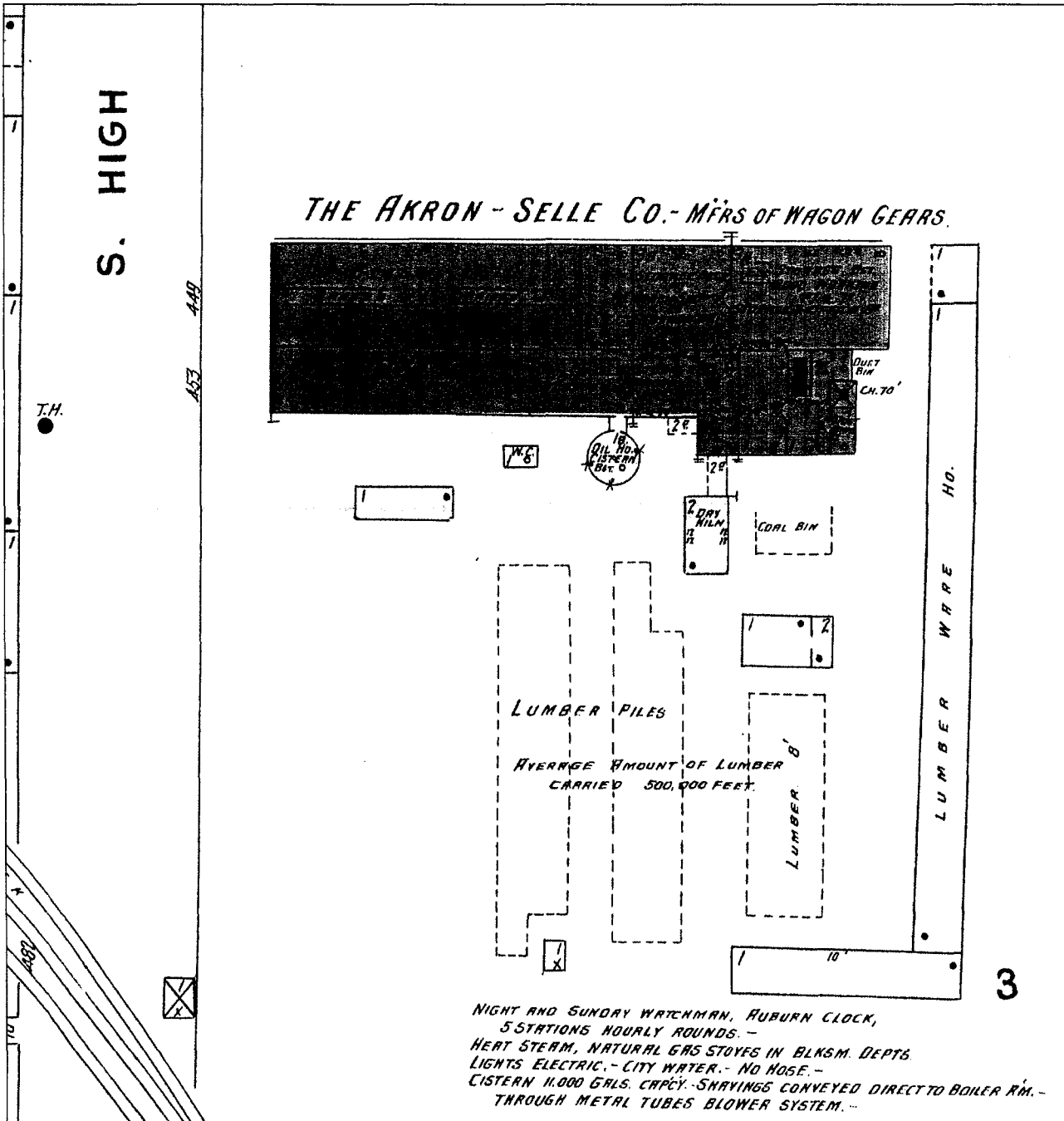

**United States Department of the Interior
National Park Service**

**NATIONAL REGISTER OF HISTORIC PLACES
CONTINUATION SHEET**

MAPS
The Selle Gear Company
Summit County, Ohio

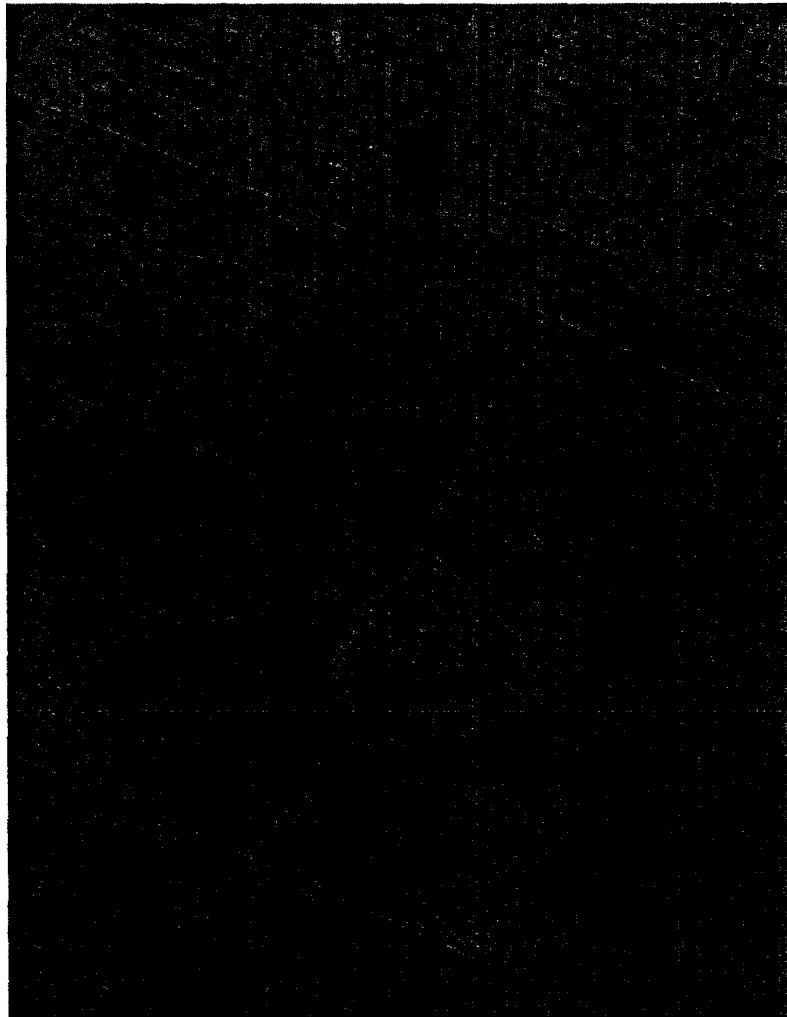

The Selle Gear Company. Akron. 1910 Atlas



December 6, 2005

Todd W. Ederer, Member
Selle Generator Works, Ltd.
34 Merz Blvd., Suite A
Akron, Ohio 44333

Dear Mr. Ederer

Congratulations on the recent listing of your property into the National Register of Historic Places!

The National Park Service, United States Department of the Interior listed the **The Selle Gear Company** at 451 S. High Street in Akron, Ohio on November 9, 2005. The nomination was made in connection with a state plan to identify and document prehistoric and historic places in Ohio which qualify for National Register status under provisions of the National Historic Preservation Act of 1966 as amended.

The Ohio Historic Preservation Office (OHPO) is available to advise you in maintaining the historic character of your property. As you know from previous mailings received from this office, there are no restrictions placed on your property following the National Register listing. However, the OHPO strongly encourages owners of historic properties to consider all options before completing work that could damage the structure or impair its historic integrity. Careful planning can facilitate the sensitive incorporation of contemporary alterations with the historic fabric. The OHPO provides free information on how to sensitively rehabilitate and repair historic properties, upon request.

Thank you for your interest in historic preservation and the National Register of Historic Places.

Sincerely,

Barbara A. Powers
Department Head
Inventory and Registration

Cc: Yolita E. Rausche, Form Preparer
Mayor Donald L. Plusquellic, City of Akron
Senator Kimberly A. Zurz, District #28
Representative Barbara A. Sykes, District #44
Northeast Four County Regional Planning & Development
Paul Graham, Ohio Department of Transportation

OHIO HISTORICAL SOCIETY

Ohio Historic Preservation Office

567 East Hudson Street, Columbus, Ohio 43211-1030 ph: 614.298.2000 fx: 614.298.2037
www.ohiohistory.org

Ohio Historic Preservation Office

National Register of Historic Places File Checklist

The following materials are contained in this file of the National Register form for:

Name: The Selle Gear Company

County: Summit

Original National Register of Historic Places nomination form

Multiple Property Nomination form

Photograph(s)

Photograph(s) (copies)

USGS map(s)

USGS map(s) (copies)

Sketch map(s)/figure(s)/exhibit(s)

Correspondence

Other patent drawings
